

# PIC Training System Manual **Rev. 2**

Department of Engineering Technology  
Electrical Engineering Technology  
Old Dominion University  
Norfolk, VA 23529

March 26, 2018

## Introduction

This is the PIC Training system that was revised from previous NSF TUES funded project to address the hands-on distance learning needs in embedded system design related courses with a research team designing a low cost training system with supporting instructional materials to assist the teaching of these concepts. Individual laboratory activities are being developed to reinforce student learning and skill development in programming concepts. This basic system format eventually will support an array of technology courses. This project involves three community colleges, Blue Ridge Community College (BRCC), VA, Tidewater Community College (TCC), VA, and Bellingham Technical College (BTC), WA and four-year universities, Old Dominion University (ODU), VA, and Wayne State University (WSU), MI in a collaborative research team effort to design and develop a specific PIC microcontroller training system with customized designed software and curriculum materials to support related engineering technology courses. The functions of the hardware and software cover different areas of engineering and technology courses and majors to maximize the use of the system.

Special thanks to Mr. Marc McComb, Academic Program Engineer at Microchip Inc., who has supported all the Microchip products used in this system.



## Training System Operations Overview

These training system operations are classified in hardware and software categories.

**Hardware:** There many elements such as LED drivers, DIP switch inputs, 7-segment connections & drivers, Max232 configurations, DAC connection, EEPROM connections, 2.4 GHZ MRF24J40MA RF module, SPI interface, LCD connections, 3\*4 and 4\*4 keypad pins pull up, I/O buffered interface connections, optical isolator connections, power FET configurations, EVUF2A Encoder, and 8 bit SPDT hardware switch

debounce are already done on the PCB (Printed Circuit Board). Users are only required to use proper interface between the PIC microcontroller pins and available modules on board to do the desired experimentations.

The hardware operations and pin description is detailed in the “Hardware Operation” section.

The physical orientation of all the connectors on the PCB are exactly the same as presented in the following graphic symbols.

- Software:**
1. The software that can run on this training system: The “PICKit2” that is downloadable from [www.microchip.com/pickit2](http://www.microchip.com/pickit2) runs on a PC USB port and its operations are detailed in the first part of “Software Operation” section.
  2. The other software is “PICKit3” that is downloadable from [www.microchip.com/pickit3](http://www.microchip.com/pickit3). To use this PICKit3 you have to use the PICKit3 Debug Express to program the PIC process on this trainer. It also runs on a PC USB port and its operations is described in the “Software Operation” part 2 sections.
  3. Another operating environment that can be used in this trainer is “Arduino”, but it needs the Zudnio module in the 40 pin ZIF socket. It also runs on a PC mini USB port and its operations is described in the “Software Operation” part 3 sections.
  4. The other operating environment is ARM M0: LPC1114FN28 that needs the LPCXpresso module to program the ARM M0 MCU. It on a PC USB port and its operations is described in the “Software Operation” part 4 sections.

Trainer with PIC MCU Programming mode with [PICKit2](#) vs. Operation mode (Please also see photo on page #6):

**S6:** LPC\_ISO\_SW DIP Switch Setting: All S6 switches should be in the OFF position when the trainer board is not used with LPCXpresso module.

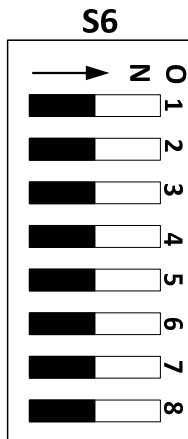

**S5: PK2\_PK3\_SW DIP Switch Setting:** Switches 1-4 should be in the ON position and 4-8 should be in the OFF position when the trainer board is intended to use with PICKit2 programming software.

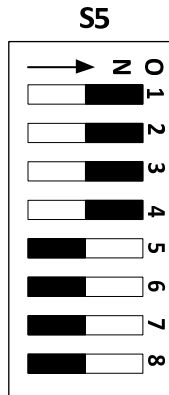

Note: The S5 and S6 switch settings should not be changed during all the operations with PICKit2 operations.

This PIC Training System Rev2 is capable to program and re-program the PIC MCU that stays in the 40 Pin ZIF socket and running user's operation software without relocating the MCU. Here are the ways of exchange between these programming and operation modes:

**Programming:**

1. Place the MCU (notch mark placed against to the top, see Page #8) properly in the 40Pin ZIF socket and lock it with the arm down.
2. Set the S1: PACKAGE\_SW package selection switches (S1) as following, also see S1 switch on Page # 10.

**(1) DIP switch 1-5 OFF and 6-10 ON → Used with 18 Pin PIC**

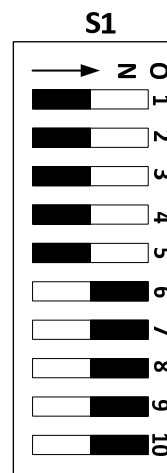

- (2) **DIP switch 1-5 ON and 6-10 OFF → Used with 28 or 40 Pin PIC**



3. Set the S4: OPER\_RB6\_RB7\_ISO\_SW, switch properly for target MCU in programming/re-programming operation mode, also see S4 switch on Pages # 10 & 11.

- (1) **SW1 OFF & SW2 ON → Use with 18 Pin PIC Programming**

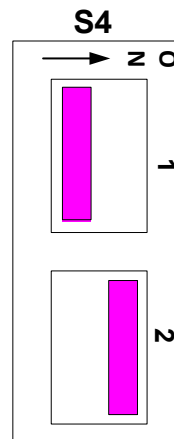

- (2) **SW1 ON & SW2 OFF → Use with 28 or 40 Pin PIC Programming**

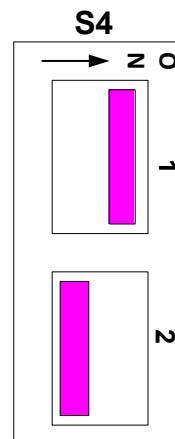

4. Connect USB cable to USB connector X1.

5. Connect the power to J1 power jack.
6. Run PICKit2 or MPLAB software
7. The software should recognize the target MCU in the 40Pin ZIF socket.
8. From here you can **Import** the .HEX file then click **Write** to program the MCU.

### Normal Operation:

1. Set **S1** and **S4** on/off for normal/evaluation operation as following:

**S4: SW1 OFF & SW2 ON → Use with all 18 Pin PIC Normal Operations**

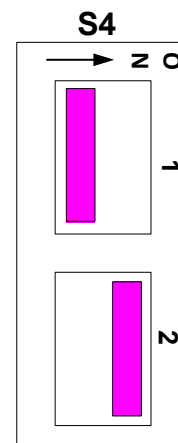
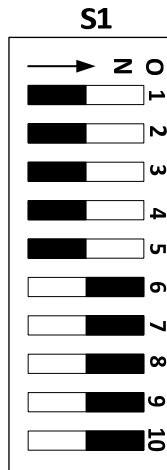

**S4: SW1 ON & SW2 OFF → Use with all 28 & 40 Pin PIC Normal Operations**

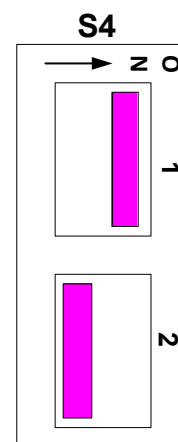
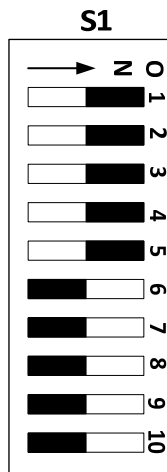

2. Simple press the S2 (for 18 pin PIC) or S3 (for 28 or 40 pin PIC) reset switch, the MCU should boot and run the loaded source code (your .HEX file).

### Re-programming:

1. Leave S1 package selection switches unchanged and set S4 for different PIC programming settings as:
  - (1) **SW1 OFF & SW2 ON → Use with 18 Pin PIC Programming**
  - (2) **SW1 ON & SW2 OFF → Use with 28 or 40 Pin PIC Programming**
2. Under PICKIT2 “Tools” manual, select “**Check Communication**”. This should stop the operation mode of the MCU and force it in programming mode. The software should recognize the target MCU in the ZIF socket.
3. If is not successful, **press and hold the RESET switch** (S2 for 18 Pin PIC or S3 for

- 28 or 40 Pin PIC) do it again, then the PICKit2 should recognize the target MCU.
4. If the target MCU still can NOT be recognized, check/do the following:
    - (1) Make sure your application interfaces are not pulled the RB6 and RB7 I/O pins down.
    - (2) If they are, then your choices are
      - (a) **Press and hold the RESET** switch (**S2** for 18 Pin PIC or **S3** for 28 or 40 Pin PIC), then click the “**Check Communication**” make sure the target MCU is recognized by the software, the re-program the MCU in following step #5, after it is done, then power down reconnect the RB6 and RB7 interfaces, then power up. The system should run with your new .HEX file, ignore a signal if it says “Verification Failed”.
      - (b) Power down the system, disconnect the RB6 and RB7 interfaces, power up then click the “**Check Communication**” make sure the target MCU is recognized by the software, the re-program the MCU in following step #5, after it is done, then power down reconnect the RB6 and RB interfaces, then power up. The system should run with your new .HEX file, ignore a signal if it says “Verification Failed”.
      - (c) Power down the system, disconnect the OSC1 and OSC2 resonator interface between SV4 and MCU oscillator pins, power up the system, then click the “**Check Communication**” make sure the target MCU is recognized by the software, the re-program the MCU in following step #5, after it is done, then power down reconnect the OSC1 and OSC2 interfaces, then power up. The system should run with your new .HEX file, ignore a signal if it says “Verification Failed”.
  5. **Press and hold the RESET switch** (**S2** for 18 Pin PIC or **S3** for 28 or 40 Pin PIC), under the main manual “**File**”, select “**Import Hex**”, choose the proper .HEX file then click on “**Write**” to re-program the target MCU. At this point you may encounter a verification fail, but the .HEX should be already programmed and the MCU should start running with your new code. Ignore a signal if it says “Verification Failed”.

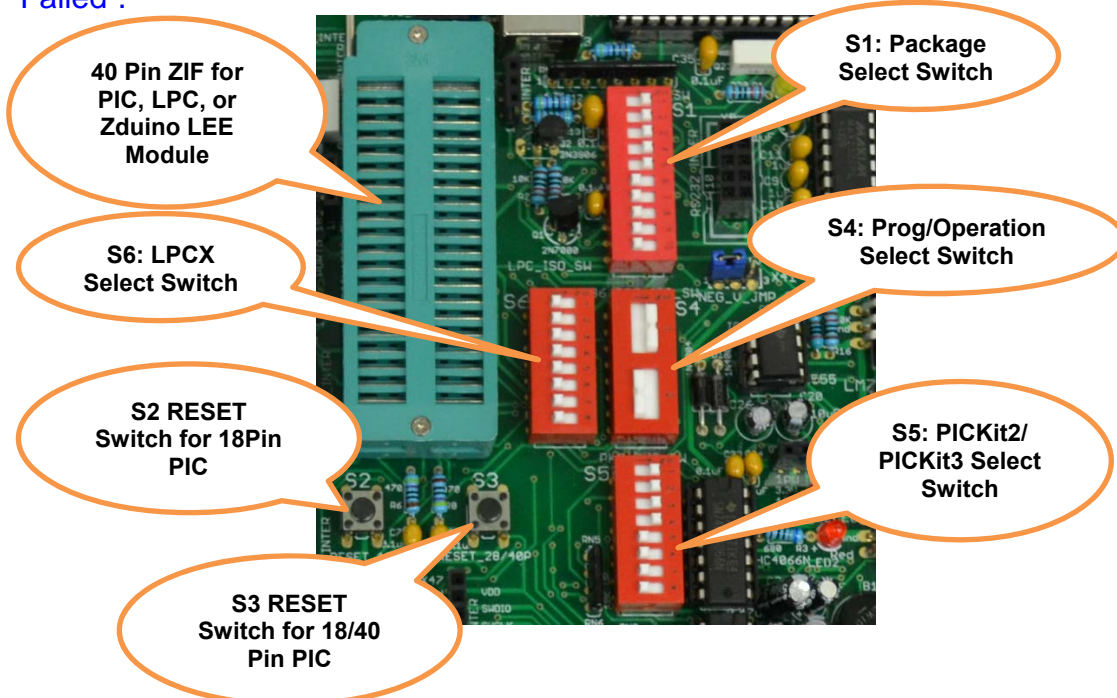



## Low Power Section

1. **40Pin ZIF Socket (IC4)**: It is a universal zero insertion force (ZIF) socket that is to host different DIP pin package PIC microcontroller for programming. The position of different pin package is to place the PIC direct against top (the movable arm side), the notch mark should be facing toward the top. The following is a graphic illustration:

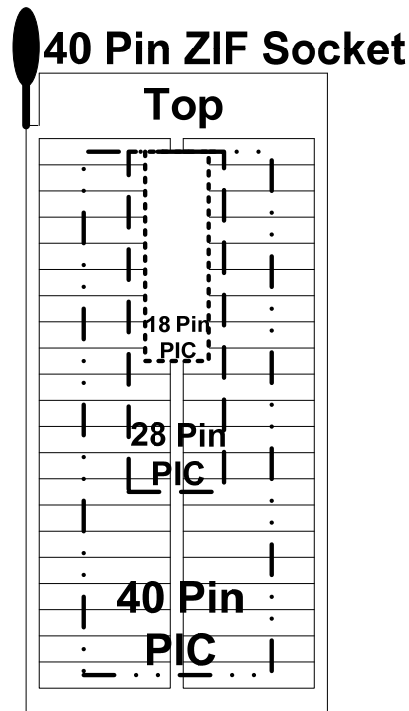

2. **Power Jack Connector (J1)**: It takes either DC or AC power (12V-15V) from a wall mount plug in power supply. The board has a bridge rectifier to take any power and regulates a +5V for normal MPU operation, a +12V for flash and EEPROM memories programming needs, and +3.3V for low power MPU and 2.4GHz wireless module. A wall mount power supply is included in the package.

**Note:** The polarity on the power jack plug make NO difference to the trainer board.

3. **Package Selection DIP Switch (PACKAGE SW, S1)**: This 10 positions DIP switch is used to selection different DIP pin package PIC for programming. The following are the choices:  
The S1 controls are:





18 Pin PIC: 1-5 Off & 6-10 On

28/40 Pin PIC: 1-5 On & 6-10 Off

(1) DIP switch 1-5 OFF and 6-10 ON → Used with 18 Pin PIC Programming

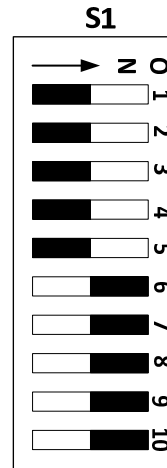

(2) DIP switch 1-5 ON and 6-10 OFF → Used with 28 or 40 Pin PIC Programming



**Note:** Be sure the power plug is disconnected before changing any setting on this DIP switch.

4. **Programming and Operation Selection DIP Switch (PROG OPER SW, S4):**  
This 2 positions DIP switch is used for programming operation of the target PIC that is inserted in the ZIF socket. The following are the choices:

The S4 controls are:

- (1) **SW1 OFF & SW2 ON →**  
**Use with 18 Pin PIC**  
**Programming**

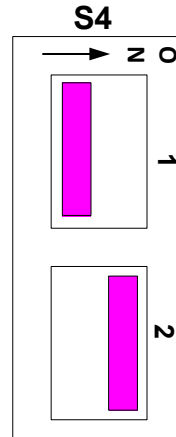

- (2) **SW1 ON & SW2 OFF →**  
**Use with 28 or 40 Pin PIC**  
**Programming**

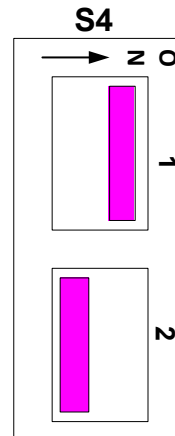

**Normal Operation:**

**Set S1 and S4 on/off as following:**  
**Use with 18 Pin PIC**

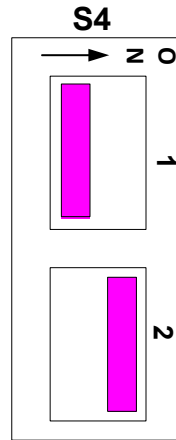
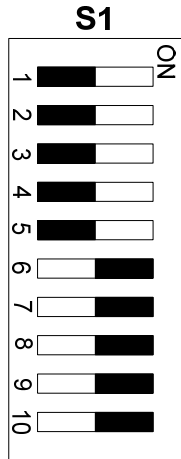

**Use with 28 or 40 Pin PIC**

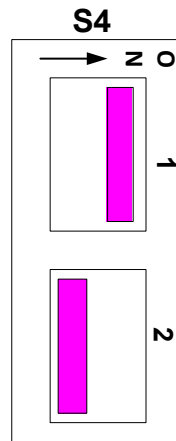
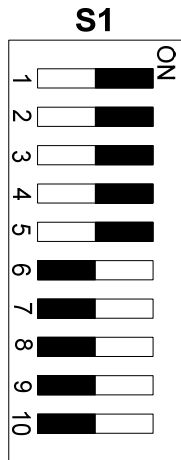

**Note:** The power should be disconnected before changing any of the switches.

**5. RESET Switch or 18 Pin PIC (S2):**

This the MCLR pin connection to the 18 pin PIC for any system RESET needs. The circuit is configured as:

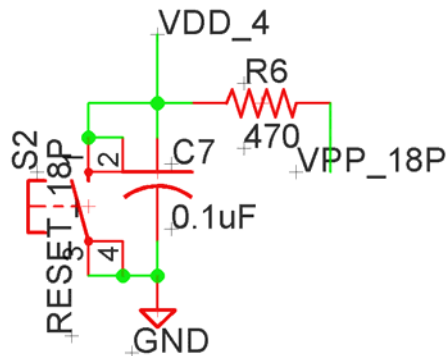

6. **RESET Switch or 28 or 40 Pin PIC (S3):**

This the MCLR pin connection to the 18 pin PIC for any system RESET needs. The circuit is configured as:

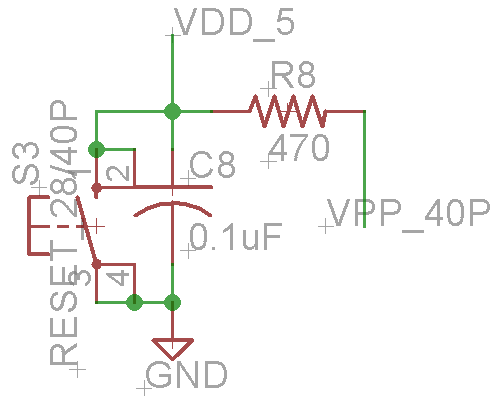

7. **8 Positions DIP Digital Input Switch (S7):** This provides 8 bits input to any experimental circuit.

The S13 pin connections are:

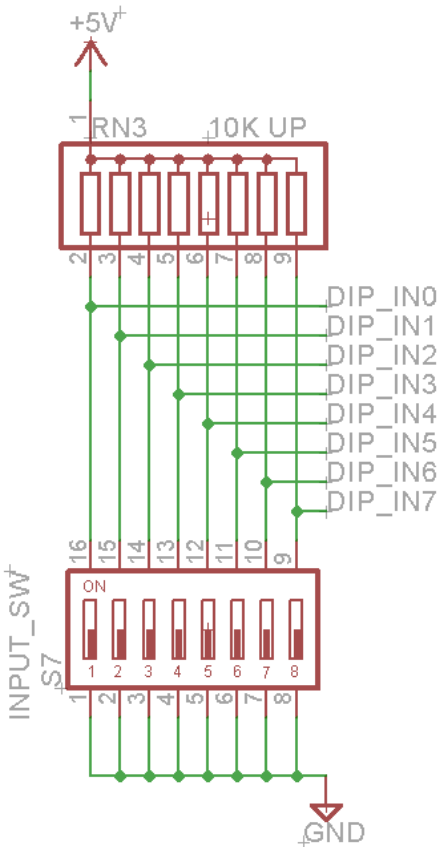

DIP Switch #1 → 10K Pull up to +5V and Yellow LED31 for Logic Indication

DIP Switch #2 → 10K Pull up to +5V and Yellow LED32 for Logic Indication

DIP Switch #3 → 10K Pull up to +5V and Yellow LED33 for Logic Indication

DIP Switch #4 → 10K Pull up to +5V and Yellow LED34 for Logic Indication

DIP Switch #5 → 10K Pull up to +5V and Yellow LED35 for Logic Indication

DIP Switch #6 → 10K Pull up to +5V and Yellow LED36 for Logic Indication

DIP Switch #7 → 10K Pull up to +5V and Yellow LED37 for Logic Indication

DIP Switch #8 → 10K Pull up to +5V and Yellow LED38 for Logic Indication

8. **IRQ Switch 0 (S8)**: This SPDT switch (with C, NC, & NO) provides the interrupt signal to any experimental circuit. There is no hardware debounce and resistor pull up or pull down, it is user's responsibility to add external component to use this switch.
9. **IRQ Switch 1 (S9)**: This SPDT switch (with C, NC, & NO) provides the interrupt signal to any experimental circuit. There is no hardware debounce and resistor pull up or pull down, it is user's responsibility to add external component to use this switch.
10. **LCD\_CONN: LCD Module Connector (SV1)**: It is used for 14 pin LCD module connection, all the 14 pin connections are available through LCD interface (X29, See Page #27) that is place by the side of the 2.2"\*6.5" breadboard. The LCD module is included in the package.

The SV1 pins connections are:

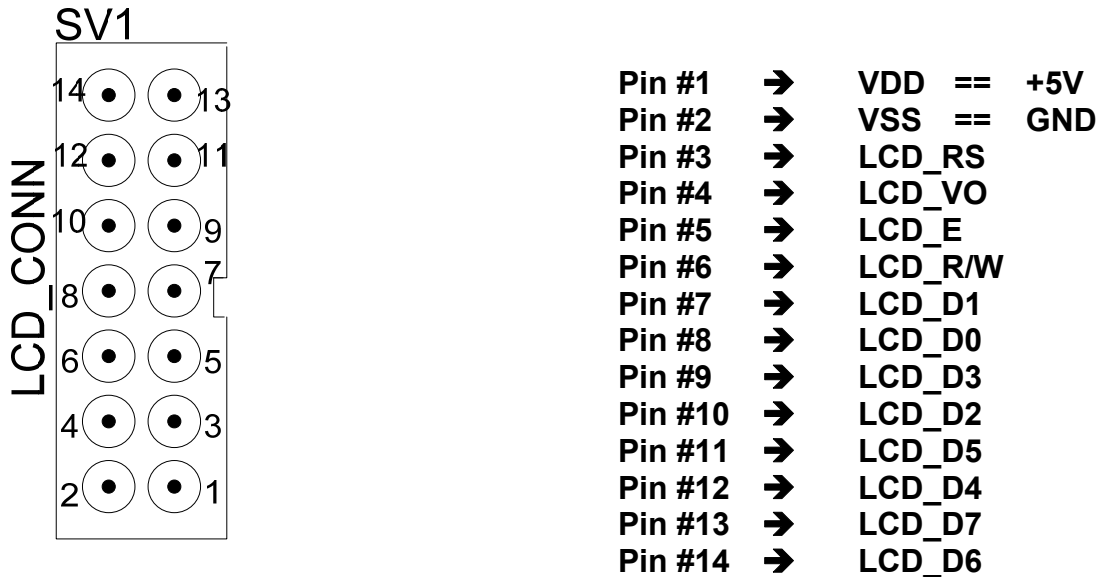

11. **KEYPAD\_CONN: 3\*4 OR 4\*4 Keypad Connector (SV2)**: It is used for a 3\*4 or 4\*4 matrix keypad connection, all 12 pins are pull high through 10K resistors. The keypad should be directly inserted into this connection socket. This keypad interface is available on X4 (See Page #18) in-line female socket connector. The 3\*4 keypad is included in the package.

The SV2 pins connections are:

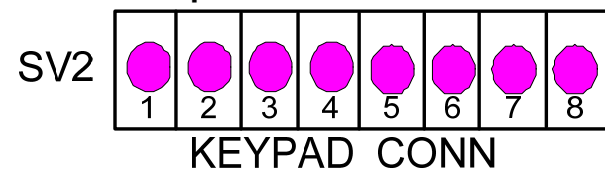

Pin #1 → 10K Pull up to +5V

- Pin #2 → 10K Pull up to +5V
- Pin #3 → 10K Pull up to +5V
- Pin #4 → 10K Pull up to +5V
- Pin #5 → 10K Pull up to +5V
- Pin #6 → 10K Pull up to +5V
- Pin #7 → 10K Pull up to +5V
- Pin #8 → 10K Pull up to +5V

**12. RESONATOR\_INTER: Resonator Interface Connector (SV4):** This is an interface for those MCUs (PIC16F84A, PIC16F877A) that need external clock signal to be built with experimental circuit on the 2.2”\*6.5” breadboard. The center GND pin already wired to the system GND trace.

The SV4 pins connections are:

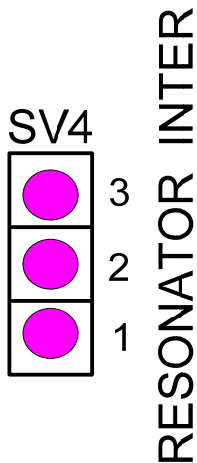

- Pin #1 → OSC1 == Resonator Pin 1
- Pin #2 → GND == Resonator Center Pin
- Pin #3 → OSC2 == Resonator Pin 2

**13. RF\_INTER1 & REF\_INTER2: MRF24J40MA 2.4 GHz Module Sockets (SV5 & SV6):** This a combination of SV5 & SV6 sockets for MRF24J40MA module connection. There is only one orientation of the module that is its antenna has to point out of the PIC Trainer board. The available interface connector is on X36 (See Page #30) This is an actual picture of this MRF24JMA, 2.4 GHz module and its associated interface pins:

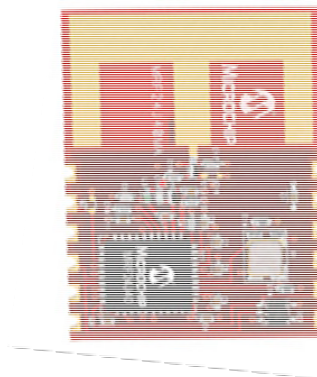
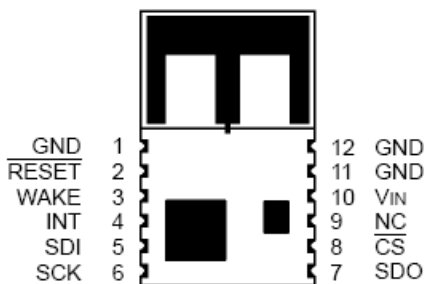

The associated circuit is:

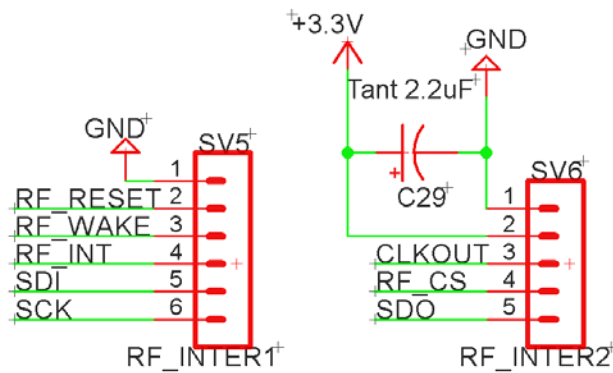

MRF24J40MA Rev3 Module

14. **PIC18F2550 on a 28 Pin Narrow Socket (IC1)**: This is a resident PIC that is used for communication to a PC via an USB port. It is supposed to be on the socket all the time. Do NOT remove this PIC MCU for any other purpose.
15. **Red LED (LED2)**: It is an indication of the present of the power source. Any time the wall mount power plug into the power jack, this RED LED will light.
16. **Yellow LED (LED1)**: It is an indication of the USB communication. When it flashes that indicates the communications processes are either in identifying the type of the PIC MCU, programming a HEX file to the PIC, reading the flash/EEPROM off the PIC, verifying the content of the flash/EEPROM of the PIC, or erasing the content of the PIC MCU.
17. **LM7805 Regulator (IC2)**: This is a +5V power regulator and it can provide +5V power up to 1A. A heat sink is mounted to this TO220 package to support the maximum output of this regulator.
18. **LM7812 Regulator (IC3)**: This is a +12V power regulator and it can provide +12V power up to 1A. A heat sink is mounted to this TO220 package to support the maximum output of this regulator.
19. **LF33CV Regulator (IC16)**: This is a +3.3V power regulator and it can provide +3.3V power up to 1A. A heat sink is mounted to this TO220 package to support the maximum output of this regulator.

**Note:** Any operation should not cause these LM7805, LM7812, or LF33CV to be hot. If the temperature is hot at these devices, the power jack should be disconnecting immediately and check for any short circuit. During the normal operation this LM7805, LM7812, & LF33CV should only be warm and touchable by a finger.

20. **USB\_CONN1: USB Connector #1 (X1):** It is an USB type B female receptacle connector that is used for regular USB communication to a PC. An USB cable with Type A-B connector is included in the package.

21. **CON1 (DB9): DB 9 Connector (X2):** This is used for a PC serial port communication to the on board MAX232 on the training system.

The X2 pins connections are:

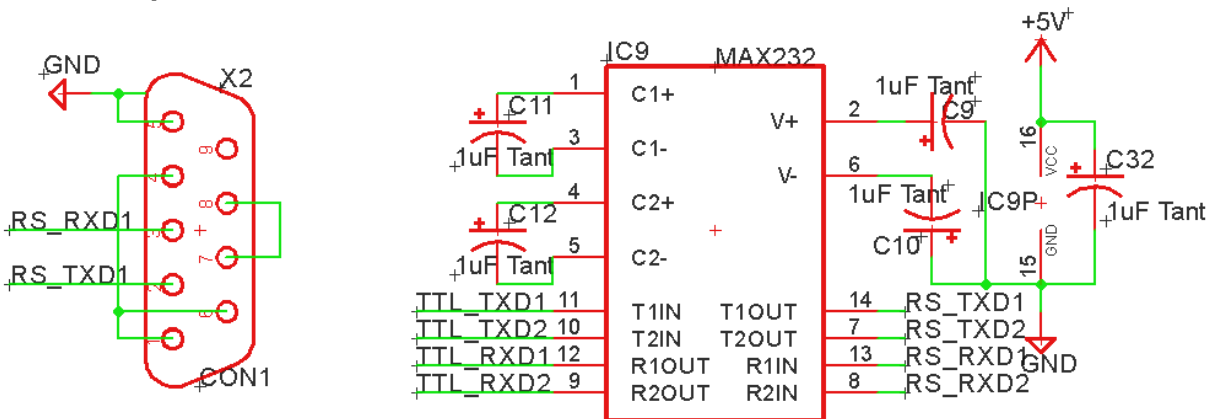

22. **PW\_JUMP\_SELECT: Jumper Selection (X2):** This is a **RED** jumper selection of either +5V or +3.3V for the regular or low power MCU that will be used on the trainer board. If you use PICKit2 or Arduinio the **RED** Jumper need to be set to +5V (**RED** Jumper on Pins #2 & #3). If you use PICKit3 or LPC the RED Jumper needs to be set to +3.3V (**RED** Jumper on Pins #1 & #2) .

PW JMP SELECT

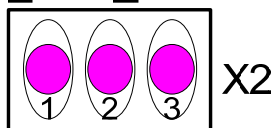

Pin #1 → +3.3V  
 Pin #2 → VDD  
 Pin #3 → +5V

**Note:** **RED** Jumper on Pins #2 & #3 → Provides +5V to VDD  
**RED** Jumper on Pins #1 & #2 → Provides +3.3V to VDD

23. **USB\_CONN2: USB Connector #2 (X3):** It is another USB type B female receptacle connector that is used for experimental USB communication to a PC or any other device. The interface connection of +D, -D, GND are already set up to the USB port pins on a PIC18F2550 that should be inserted in the ZIF socket.

**Note:** This is not a replacement of the programming USB communication port as X1 that is used for the dedicated PIC18F2550 on the training system. Its intent is for needed lab experimentation uses.



**24. 3\*4/4\*4 KEYPAD\_INTER: Keypad Interface Connector (X4):** This is an in-line female socket interface connector for the 3\*4 keypad to be used with experimental circuit on the 2.2"\*6.5" breadboard.

The X4 pins connections are:

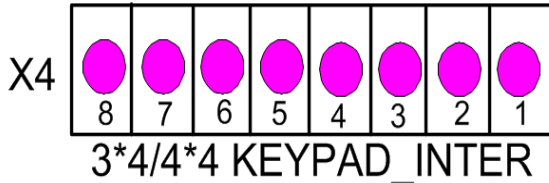

- Pin #1 → 10K Pull up to +5V
- Pin #2 → 10K Pull up to +5V
- Pin #3 → 10K Pull up to +5V
- Pin #4 → 10K Pull up to +5V
- Pin #5 → 10K Pull up to +5V
- Pin #6 → 10K Pull up to +5V
- Pin #7 → 10K Pull up to +5V
- Pin #8 → 10K Pull up to +5V

**25. RS232\_INTER: MAX232 Interface Connector (X5):** This is an interface for the MAX232 be used as RS232-TTL communication experimental circuit on the 2.2"\*6.5" breadboard. The MAX232 has all the needed capacitors and power to function properly.

The X5 pins connections are:

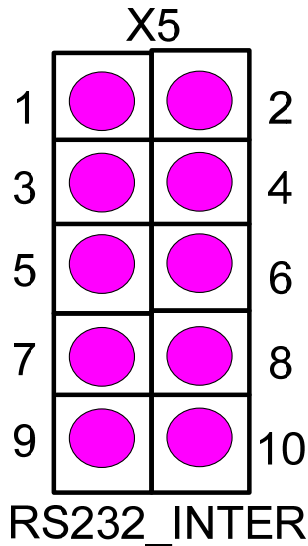

- Pin #1 → TTL\_TXD1
- Pin #2 → RS\_TXD1
- Pin #3 → TTL\_TXD2
- Pin #4 → RS\_TXD2
- Pin #5 → TTL\_RXD1
- Pin #6 → RS\_RXD1
- Pin #7 → TTL\_RXD2
- Pin #8 → RS\_RXD2
- Pin #9 → GND
- Pin #10 → GND

The associated circuit is:

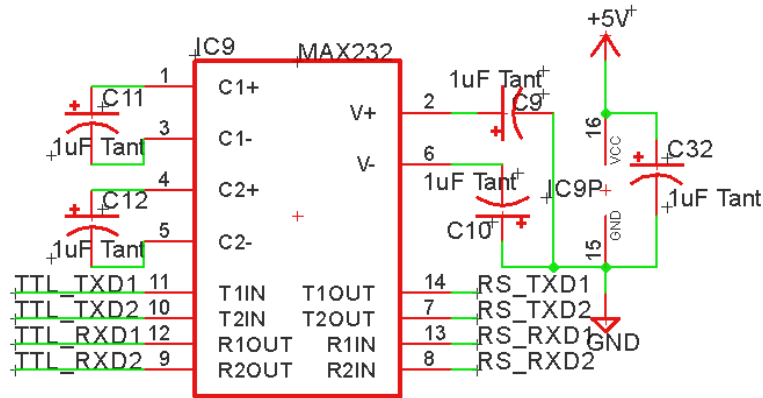

**26. LED\_INTER: LED Interface Connector (X6):** These are signals to control 8 on board LEDs (LED3-LED10) to be used on experimental circuit on the 2.2”\*6.5” breadboard.

The X6 pins connections are:

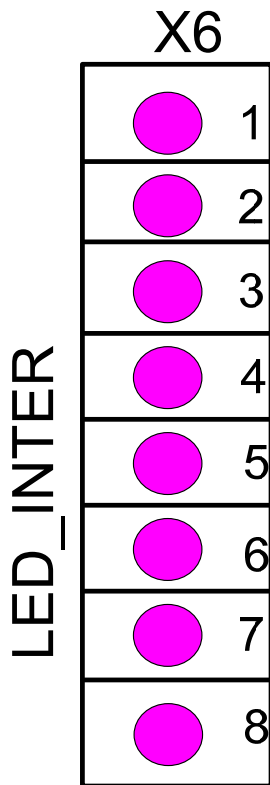

- Pin #1 → LED\_OUT0, Control Red LED 3
- Pin #2 → LED\_OUT1, Control Yellow LED 4
- Pin #3 → LED\_OUT2, Control Green LED 5
- Pin #4 → LED\_OUT3, Control Red LED 6
- Pin #5 → LED\_OUT4, Control Yellow LED 7
- Pin #6 → LED\_OUT5, Control Green LED 8
- Pin #7 → LED\_OUT6, Control Yellow LED 9
- Pin #8 → LED\_OUT7, Control Yellow LED 10

The associated circuits are:

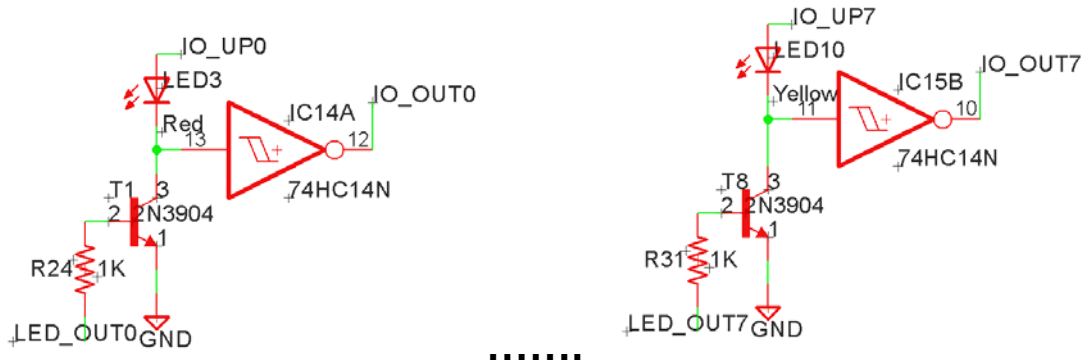

**27. OPAMP\_INTER: OPamp Interface Connector (X7):** This is an interface for MCP6024 that is a general Operational Amplifier to be built with experimental circuit on the 2.2”\*6.5” breadboard. This MCP6014 has four OPamps in one package for any conditional circuit to be used.

The X7 pins connections are:

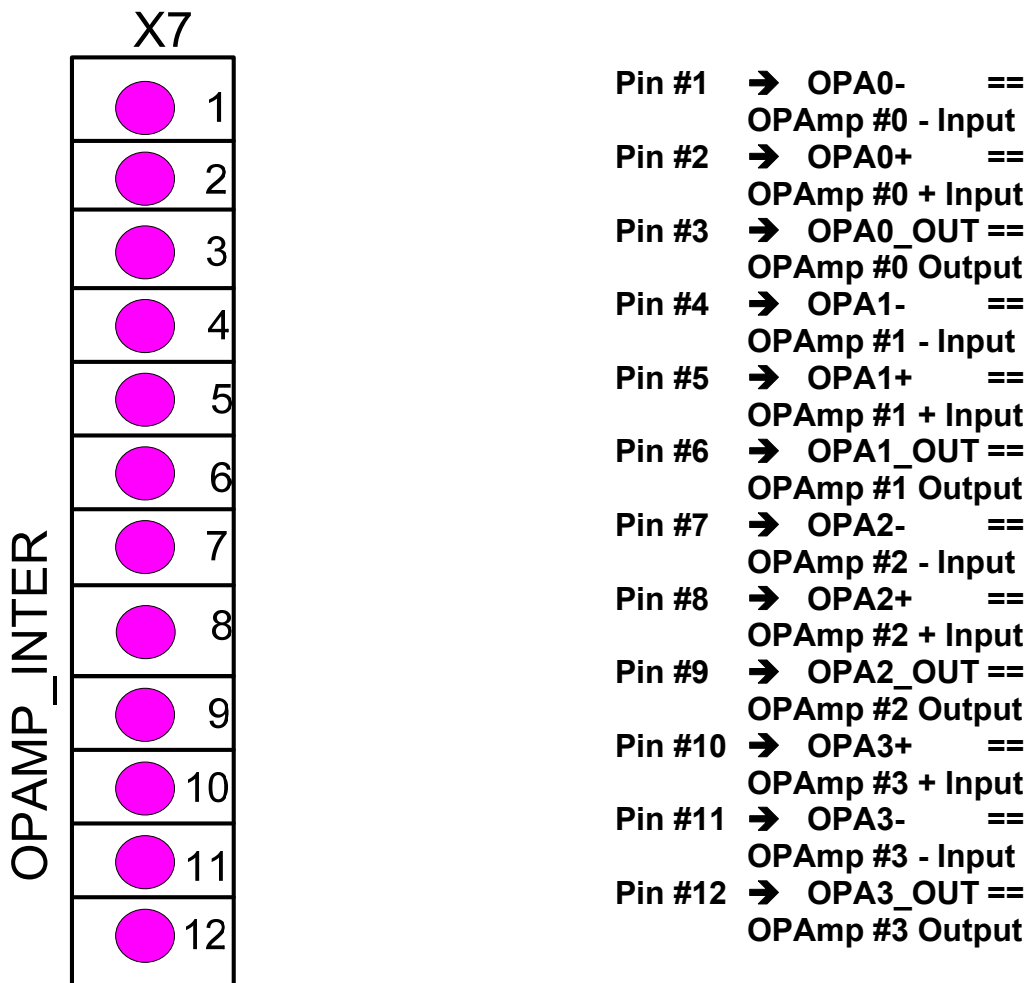

28. PORTA\_18P\_INTER: Port A 18 Pin Interface Connector (X8): This provides PIC16F84A and PIC16F88 PORTA signal interface to be used on experimental circuit on the 2.2”\*6.5” breadboard.

The X8 pins connections are:

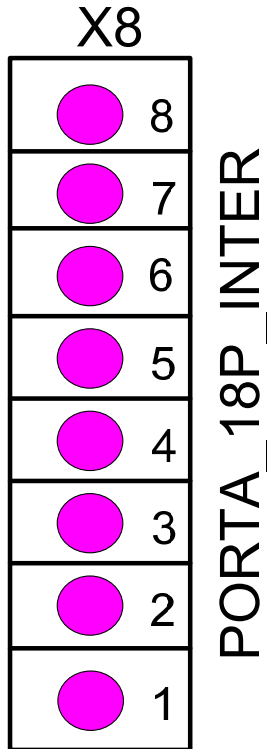

- Pin #1 → CLK\_40P\_ZIF ==  
18P: RA0, 40P: RB6/PGC
- Pin #2 → DAT\_40P\_ZIF ==  
18P: RA1, 40P: RB7/PGD
- Pin #3 == VPP\_40P ==  
18P: RA2,  
40P: MCLR/VPP
- Pin #4 → RA3\_18P ==  
18P: RA3, 40P: RA0/AN0
- Pin #5 → RA4\_18P ==  
18P: RA4/TOCKI,  
40P: RA1/AN1
- Pin #6 → VPP\_18P ==  
18P: MCLR,  
40P: RA2/AN2/VREF-/CVREF
- Pin #7 → RA6\_OSC2\_18P ==  
18P: RA6/OSC2/CLKOUT,  
40P: RB4
- Pin #8 → RA7\_OSC1\_18P ==  
18P: RA7/OSC1/CLKIN,  
40P: RB5

29. SPI\_INTER SPI: Interface Connector (X9): This is an interface for 25LC256P (32KB EEPROM) or MCP4822 (DAC) that is SPI signal control to be built with experimental circuit on the 2.2”\*6.5” breadboard.

The X9 pins connections are: (If the MCP 4822 that has two DAC channels is used on the training system.)

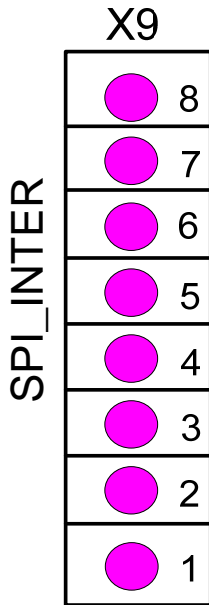

- Pin #1 → EE\_CS ==  
EEPROM Chip Select
- Pin #2 → SCK ==  
SPI Clock Signal
- Pin #3 → SDO ==  
SPI Data Out
- Pin #4 → SDI ==  
SPI Data In
- Pin #5 → LDAC ==  
DAC LDAC Signal
- Pin #6 → OUTA ==  
DAC Channel A Out
- Pin #7 → OUTB ==  
DAC Channel B Out
- Pin #8 → DAC\_CS ==  
DAC Chip Select

The X9 pins connections are: (If the MCP 4821 that has one DAC channel is used on the training system.)

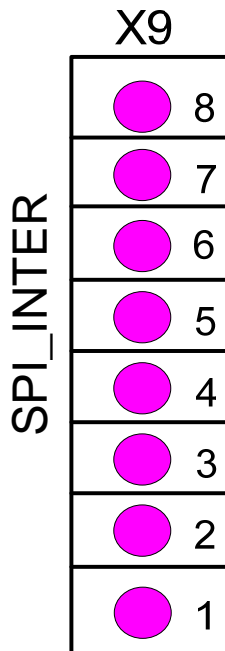

- Pin #1 → EE\_CS ==  
EEPROM Chip Select
- Pin #2 → SCK ==  
SPI Clock Signal
- Pin #3 → SDO ==  
SPI Data Out
- Pin #4 → SDI ==  
SPI Data In
- Pin #5 → LDAC ==  
DAC LDAC Signal
- Pin #6 → OUTA ==  
DAC Channel A Out
- Pin #7 → SHDN ==  
DAC Channel A Shut Down  
Control
- Pin #8 → DAC\_CS ==  
DAC Chip Select

**30. PORTB\_18P\_INTER: Port B 18 Pin Interface Connector (X10):** This provides PIC16F84A and PIC16F88 PORTB signal interface to be used on experimental circuit on the 2.2”\*6.5” breadboard.

The X10 pins connections are:

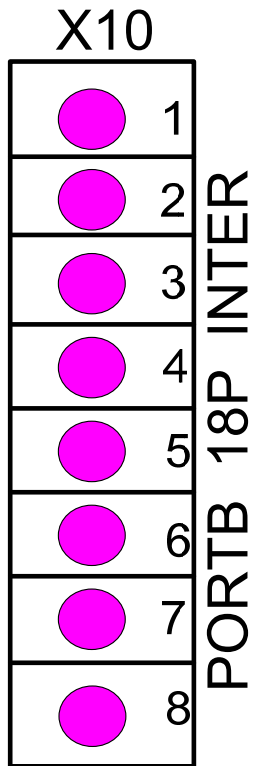

- Pin #1 → RB0\_18P ==  
18P: RB0/INT0,  
40P: RB4/TOCK1C1OUT
- Pin #2 → RB1\_18P ==  
18P: RB1,  
40P: RA5/AN4/SS/C2OUT
- Pin #3 → RB2\_18P ==  
18P: RB2,  
40P: RE0/RD/AN5
- Pin #4 → RB3\_18P ==  
18P: RB3,  
40P: RE1/WR/AN6
- Pin #5 → VDD\_40P ==  
18P: RB4, 40P: VDD
- Pin #6 → RB5\_18P ==  
18P: RB5, 40P: RB0/INT
- Pin #7 → CLK\_18P\_ZIF ==  
18P: RB6, 40P: RB1
- Pin #8 → DAT\_18P\_ZIF ==  
18P: RB7, 40P: RB2

31. **PORTA\_18P\_INTER: Port A 40 Pin Interface Connector (X11):** This provides PIC16F877A PORTA signal interface to be used on experimental circuit on the 2.2”\*6.5” breadboard.

The X11 pins connections are:

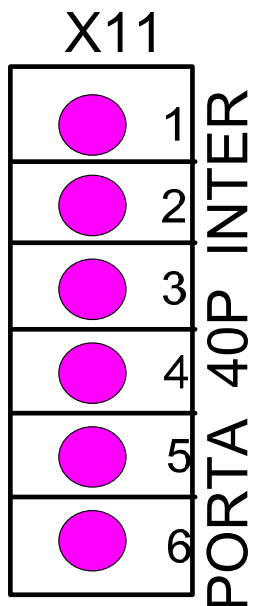

- Pin #1 → RA3\_18P ==  
40P: RA0/AN0, 18P: RA3
- Pin #2 → RA4\_18P ==  
40P: RA1/AN1, 18P: RA4
- Pin #3 → VPP\_18P ==  
40P: RA2/AN2/VREF-/CVREF,  
18P: MCLR
- Pin #4 → GND\_18P ==  
40P: RA3/AN3/VREF+,  
18P: VSS
- Pin #5 → RB0\_18P ==  
40P: RA4/TOCKI/C1OUT ,  
18P: RB0/INT
- Pin #6 → RB1\_18P ==  
40P: RA5/AN4/SS/C2OUT,  
18P: RB1

32. **PORTB\_40P\_INTER: Port B 40 Pin Interface Connector (X12):** This provides PIC16F877A PORTB signal interface to be used on experimental circuit on the 2.2”\*6.5” breadboard.

The X12 pins connections are:

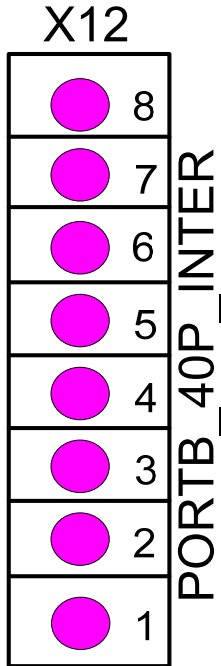

- Pin #1 → RB5\_18P ==  
40P: RB0/INT, 18P: RB5
- Pin #2 → RB6\_18P ==  
40P: RB1, 18P: RB6
- Pin #3 → RB7\_18P ==  
40P: RB2, 18P: RB7
- Pin #4 → VDD\_18P ==  
40P: RB3/PGM, 18P: VDD
- Pin #5 → RA6\_OSC2\_18P ==  
40P: RB4, 18P: OSC2/  
CLKOUT
- Pin #6 → RA7\_OSC1\_18P ==  
40P: RB5, 18P: OSC1/  
CLKIN
- Pin #7 → RB6\_40P ==  
40P: RB6/RB6/PGC, 18P: RA0
- Pin #8 → RB7\_40P ==  
40P: RB7/PGD, 18P: RA1

33. **PORTC\_40P\_INTER: Port C 40 Pin Interface Connector (X13):** This provides PIC16F877A PORTC signal interface to be used on experimental circuit on the 2.2”\*6.5” breadboard.

The X13 pins connections are:

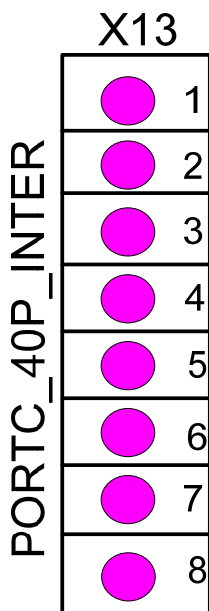

- Pin #1 → RC0\_40P ==  
40P: RC0/T1OSO/T1CKI
- Pin #2 → RC1\_40P ==  
40P: RC1/T1OSI/CCP2
- Pin #3 → RC2\_40P ==  
40P: RC2/CCP1
- Pin #4 → RC3\_40P ==  
40P: RC3/SCK/SCL
- Pin #5 → RC4\_40P ==  
40P: RC4/SDI/SDA
- Pin #6 → RC5\_40P ==  
40P: RC5/SDO
- Pin #7 → RC6\_40P ==  
40P: RC6/TX/CK
- Pin #8 → RC7\_40P ==  
40P: RC7/RX/DT

34. **PORTD\_40P\_INTER: Port D 40 Pin Interface Connector (X14):** This provides PIC16F877A PORTD signal interface to be used on experimental circuit on the 2.2”\*6.5” breadboard.

The X14 pins connections are:

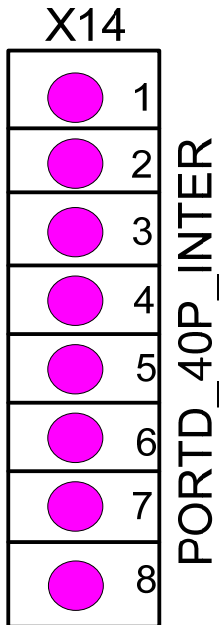

- Pin #1 → RD0\_40P ==  
40P: RD0/PSP0
- Pin #2 → RD1\_40P ==  
40P: RD1/PSP1
- Pin #3 → RD2\_40P ==  
40P: RD2/PSP2
- Pin #4 → RD3\_40P ==  
40P: RD3/PSP3
- Pin #5 → USB\_D- ==  
40P: RD4/PSP4, 28P: USB D-
- Pin #6 → USB\_D+ ==  
40P: RD5/PSP5, 28P: USB D+
- Pin #7 → RD6\_40P ==  
40P: RD6/PSP6
- Pin #8 → RD7\_40P ==  
40P: RD7/PSP7

35. **PORTE\_40P\_INTER: Port E 40 Pin Interface Connector (X15):** This provides PIC16F877A PORTE signal interface to be used on experimental circuit on the 2.2”\*6.5” breadboard.

The X15 pins connections are:

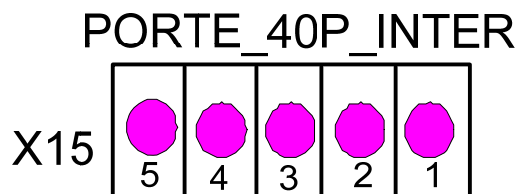

- Pin #1 → RB2\_18P == 40P: RE0/RD/AN5
- Pin #2 → RB3\_18P == 40P: RE1/WR/AN6
- Pin #3 → RE2\_40P == 40P: RE2/CS/AN7
- Pin #4 → OSC1\_40P == 40P: OS1I/CLKI
- Pin #5 → OSC2\_40P == 40P: OSC2/CLKO

36. **+POWER\_CONN: DC Power Source (X27):** This +5V power source that is on two terminal block posts (one for +5V the other for GND) for providing power source to any experimental circuit on the 2.2”\*6.5” breadboard.

The X27 pins connections are:



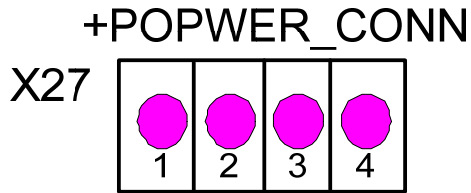

Pin 1 & Pin 2 → +5V  
 Pin 3 & Pin 4 → GND

**37. DB\_SWITCH\_INTER: Debounced Switches Connector (X28):** This is an interface debounced SPDT switches of S10-S17 to be used with experimental circuit on the 2.2”\*6.5” breadboard.

The X28 pins connections are:

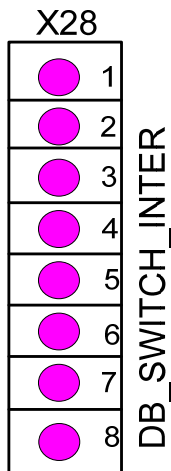

- Pin #1 → DB\_SW0 == Controlled by S10
- Pin #2 → DB\_SW1 == Controlled by S11
- Pin #3 → DB\_SW2 == Controlled by S12
- Pin #4 → DB\_SW3 == Controlled by S13
- Pin #5 → DB\_SW4 == Controlled by S14
- Pin #6 → DB\_SW5 == Controlled by S15
- Pin #7 → DB\_SW6 == Controlled by S16
- Pin #8 → DB\_SW7 == Controlled by S17

The associated circuit of these 8 hardware debounced switches are:

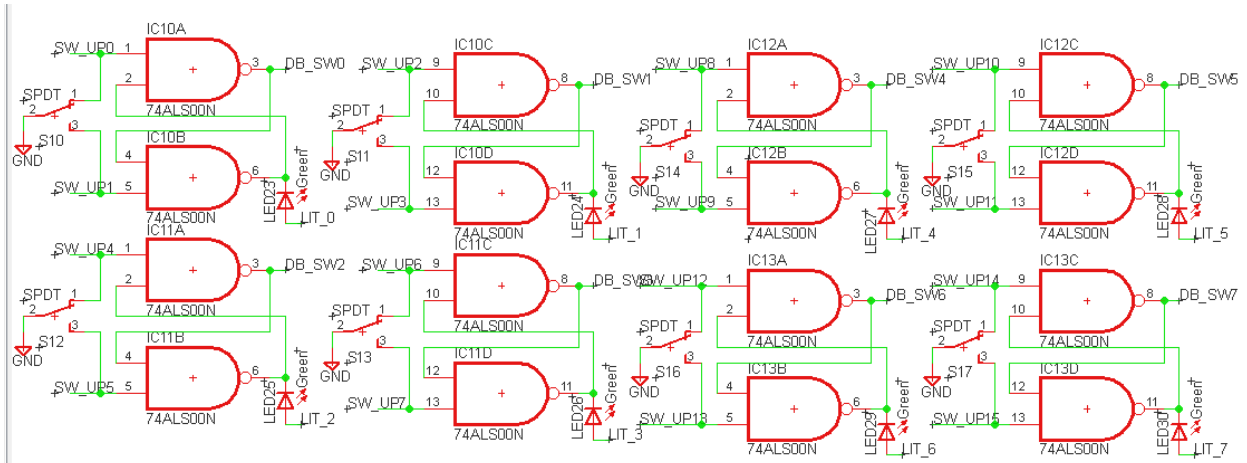

**38. LCD\_INTER: LCD Interface Connector (X29):** This is an interface for the LCD to be used with experimental circuit on the 2.2”\*6.5” breadboard.

The X29 pins connections are:

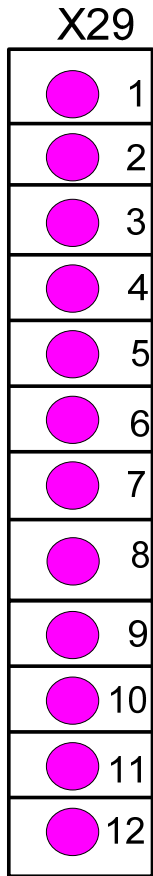

LCD\_INTER

- Pin #1 → LCD\_D0 (LCD Pin #7)
- Pin #2 → LCD\_D1 (LCD Pin #8)
- Pin #3 → LCD\_D2 (LCD Pin #9)
- Pin #4 → LCD\_D3 (LCD Pin #10)
- Pin #5 → LCD\_D4 (LCD Pin #11)
- Pin #6 → LCD\_D5 (LCD Pin #12)
- Pin #7 → LCD\_D6 (LCD Pin #13)
- Pin #8 → LCD\_D7 (LCD Pin #14)
- Pin #9 → LCD\_RS (LCD Pin #4)
- Pin #10 → LCD\_E (LCD Pin #6)
- Pin #11 → LCD\_R/W (LCD Pin #5)
- Pin #12 → LCD\_VO (LCD Pin #3)

**Note:** LCD Pin #1, Vss, is Grounded and LCD Pin #2, Vdd is Powered by +5V on the board.

39. **POT1\_INTER: Potentiometer 1 Interface Connector (X30):** These are signals from 10K  $\Omega$  Trim Potentiometer 1 connector for any adjustable voltage signal that can be interfaced to experimental circuit on the 2.2”\*6.5” breadboard.

The X30 pins connections are:

POT1\_INTER

X30

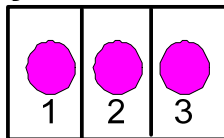

- Pin #1 → One end of the 10K  $\Omega$  Pot
- Pin #2 → Center wiper of the Pot 1
- Pin #3 → The other end of the 10K  $\Omega$  Pot

40. **ENCODER\_INTER: GS Encoder Interface Connector (X31):** These are output signals from the GS Encoder that can be interfaced to experimental circuit on the 2.2”\*6.5” breadboard. The GS Encoder does not come with the board and user has to place the part (EVEGC2 or other from Panasonic EVE series) for a specific application.

The X31 pins connections are:

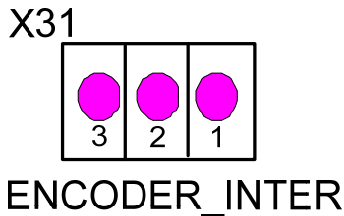

- Pin #1 → SINGAL\_A
- Pin #2 → SIGNAL\_B
- Pin #3 → GND

The associate circuit is presented as following:

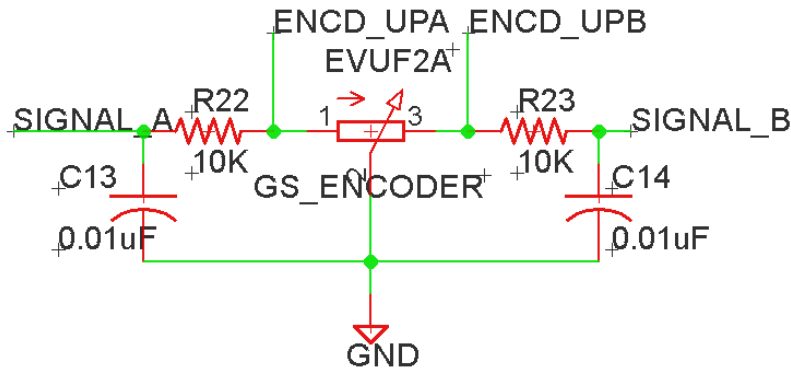

**41. DIP\_SW\_INPUT\_INTER: 8 Positions DIP Digital Input Switch Interface Connector(X32):** This is an interface for the 8 bit DIP switch to be used as inputs for experimental circuit on the 2.2”\*6.5” breadboard.

The X32 pins connections are:

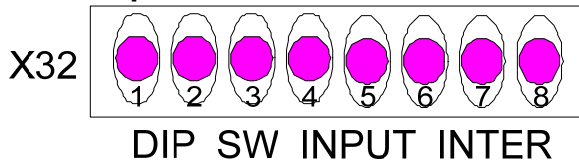

- Pin #1 → DIP Switch #1 Down = GND/Lo, Up = +5V/Hi
- Pin #2 → DIP Switch #2 Down = GND/Lo, Up = +5V/Hi
- Pin #3 → DIP Switch #3 Down = GND/Lo, Up = +5V/Hi
- Pin #4 → DIP Switch #4 Down = GND/Lo, Up = +5V/Hi
- Pin #5 → DIP Switch #5 Down = GND/Lo, Up = +5V/Hi
- Pin #6 → DIP Switch #6 Down = GND/Lo, Up = +5V/Hi
- Pin #7 → DIP Switch #7 Down = GND/Lo, Up = +5V/Hi
- Pin #8 → DIP Switch #8 Down = GND/Lo, Up = +5V/Hi

**42. 7SEG\_INTER: 7 Segment Interface Connector (X33):** This is an interface for data signal to all 4 of the 7 segment displays (common Anode type) experimental circuit on the 2.2”\*6.5” breadboard. To activate one of the four 7 segment, a proper activation signal on the driver connector should be low.

The X33 pins connections are:

X33

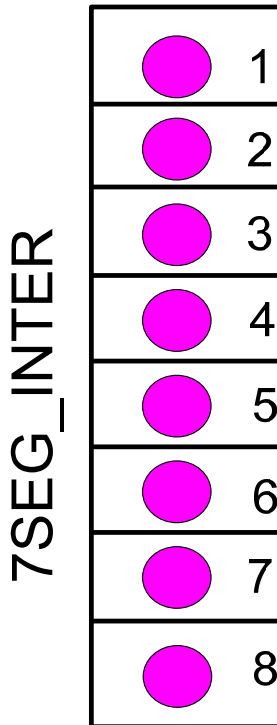

Pin #1 → Segment **a** thru 220Ω Current Limit, Output Lo to Turn on

Pin #2 → Segment **b** through 220Ω Current Limit, Output Lo to Turn on

Pin #3 → Segment **c** through 220Ω Current Limit, Output Lo to Turn on

Pin #4 → Segment **d** through 220Ω Current Limit, Output Lo to Turn on

Pin #5 → Segment **e** through 220Ω Current Limit, Output Lo to Turn on

Pin #6 → Segment **f** through 220Ω Current Limit, Output Lo to Turn on

Pin #7 → Segment **g** through 220Ω Current Limit, Output Lo to Turn on

Pin #8 → Segment **dp** through 220Ω Current Limit, Output Lo to Turn on

**43. 7SEG\_DR\_INTER: 7 Segment Driver Interface Connector (X34):** This is a driver signal interface to activate one of the four 7 segment display experimental circuit on the 2.2”\*6.5” breadboard.

The X34 pins connections are:

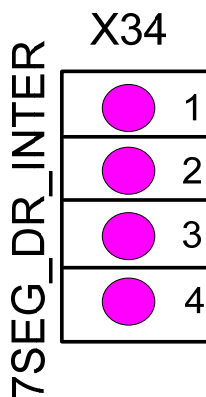

Pin #1 → Segment #0 On/Off Control, Output Lo to Turn on

Pin #2 → Segment #1 On/Off Control, Output Lo to Turn on

Pin #3 → Segment #2 On/Off Control, Output Lo to Turn on

Pin #4 → Segment #3 On/Off Control, Output Lo to Turn on

The following schematic is what was implemented on the trainer board:

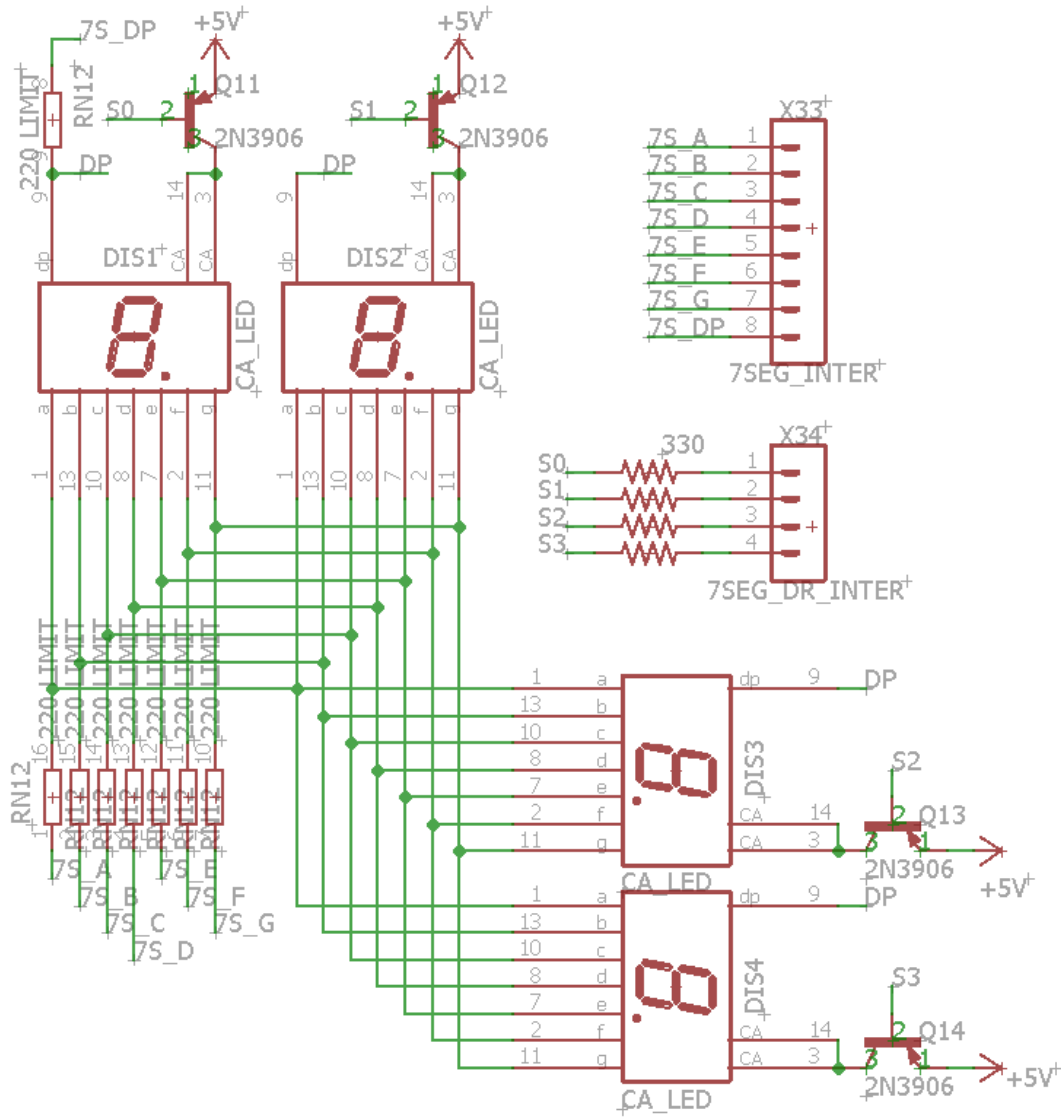

**44. IRQ\_SW\_INTER: IRQ Switch 0 Interface Connector (X35):** This is an interface for the SPDT switch to be used as inputs for interrupt experimental circuit on the 2.2"×6.5" breadboard. The first 3 connections belong to IRQ Switch 0.

The X35 pins connections are:

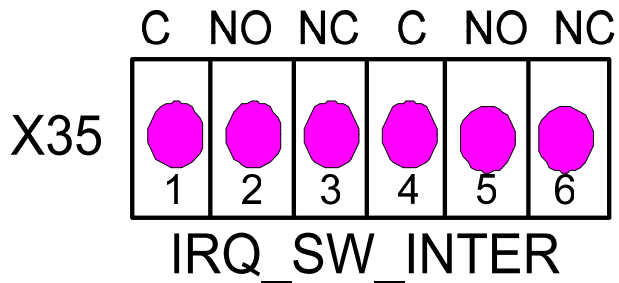

- Pin #1 → IRQ\_SW0 C (Common)
- Pin #2 → IRQ\_SW0 NO (Normal Open)
- Pin #3 → IRQ\_SW0 NC (Normal Close)
- Pin #4 → IRQ\_SW1 C (Common)
- Pin #5 → IRQ\_SW1 NO (Normal Open)
- Pin #6 → IRQ\_SW1 NC (Normal Close)

45. **RF\_SPI\_INTER: 2.4 GHz Module Interface Connector (X36):** This is a standard SPI interface for 2.4GHz, MRF24J40MA Module interface for wireless communication on the 2.2”\*6.5” breadboard.

The X36 pins connections are:

X36

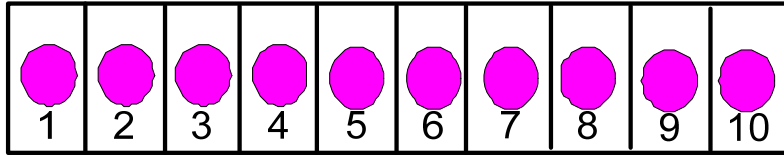

RF\_SPI\_INTER

- Pin #1 → RF\_RESET
- Pin #2 → RF\_WAKE
- Pin #3 → RF\_INT
- Pin #4 → SDO
- Pin #5 → SCK
- Pin #6 → CLKOUT
- Pin #7 → RF\_CS
- Pin #8 → SDI
- Pin #9 → VDD
- Pin #10 → GND

The associate circuits of these input/SPI interfaces are presented as following:

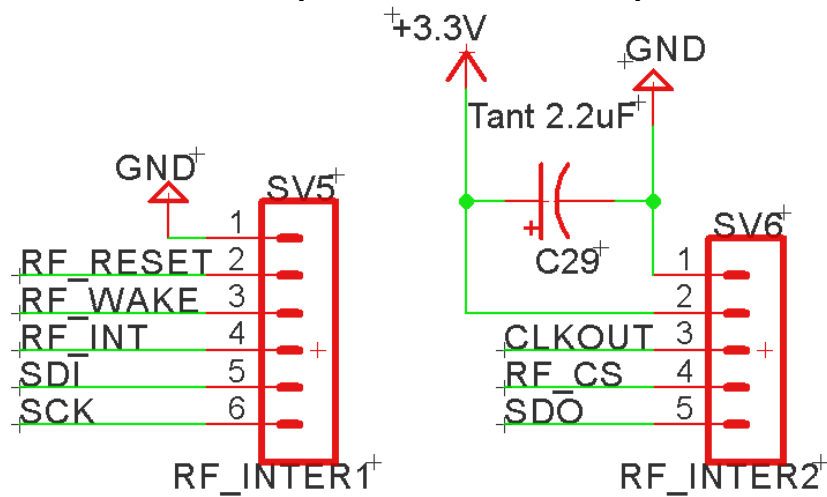

MRF24J40MA Rev3 Module

46. **IO\_OUT\_INTER: DB BUF IO Interface Connector (X37):** These are buffered signals from the LEDs (#3 - #10) that can be used to drive any input device on experimental circuit on the 2.2”\*6.5” breadboard.

The X37 pins connections are:

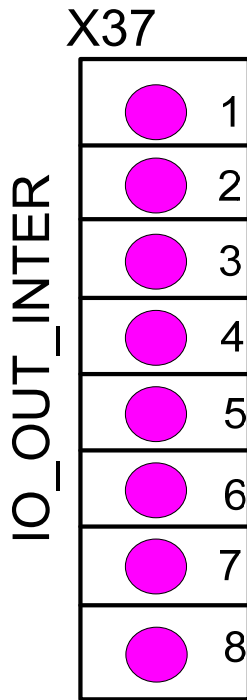

- Pin #1 → IO\_OUT0
- Pin #2 → IO\_OUT1
- Pin #3 → IO\_OUT2
- Pin #4 → IO\_OUT3
- Pin #5 → IO\_OUT4
- Pin #6 → IO\_OUT5
- Pin #7 → IO\_OUT6
- Pin #8 → IO\_OUT7

The associated circuits from IO\_OUT0 to IO\_OUT7 signals are:

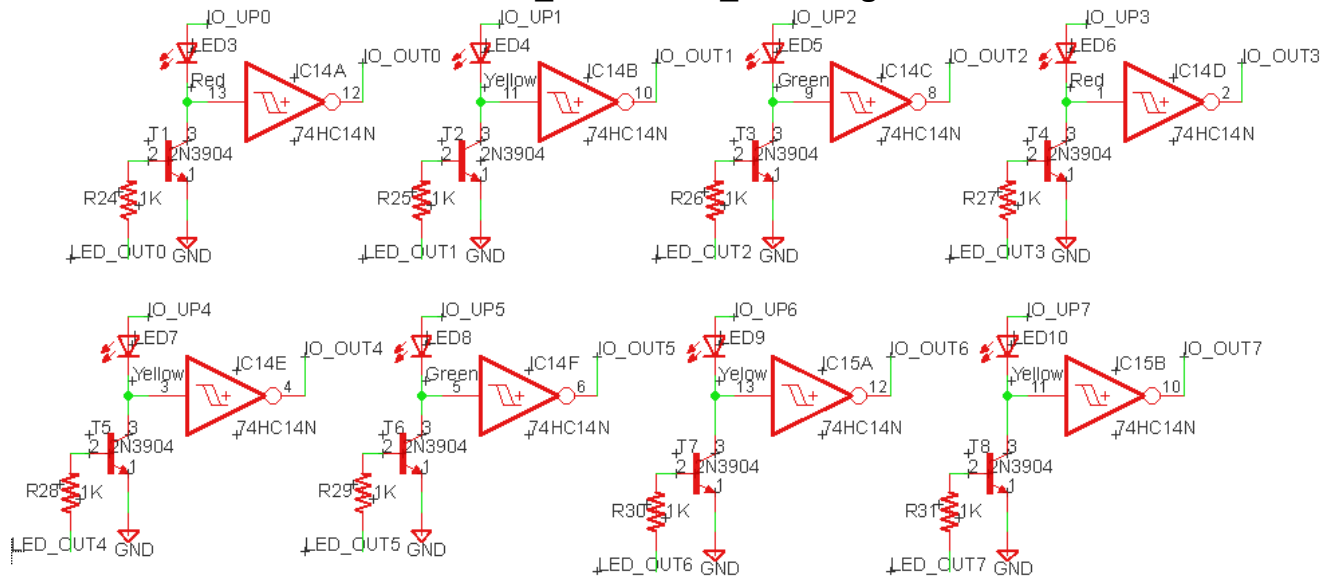

**47. IO\_DOUT\_INTER: IO Interface Connector (X38):** These are signals to the optical isolators that are used to drive the high power FETs.

The X38 pins connections are:

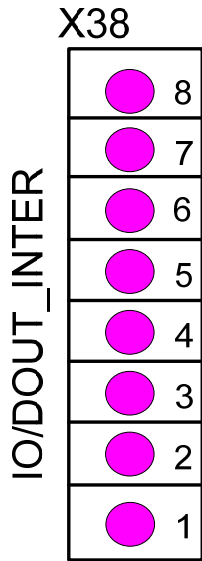

- Pin #1 → IO\_0
- Pin #2 → IO\_1
- Pin #3 → IO\_2
- Pin #4 → IO\_3
- Pin #5 → IO\_4
- Pin #6 → IO\_5
- Pin #7 → IO\_6
- Pin #8 → IO\_7

The associate circuits for these low power DOUT signals and FETs are:

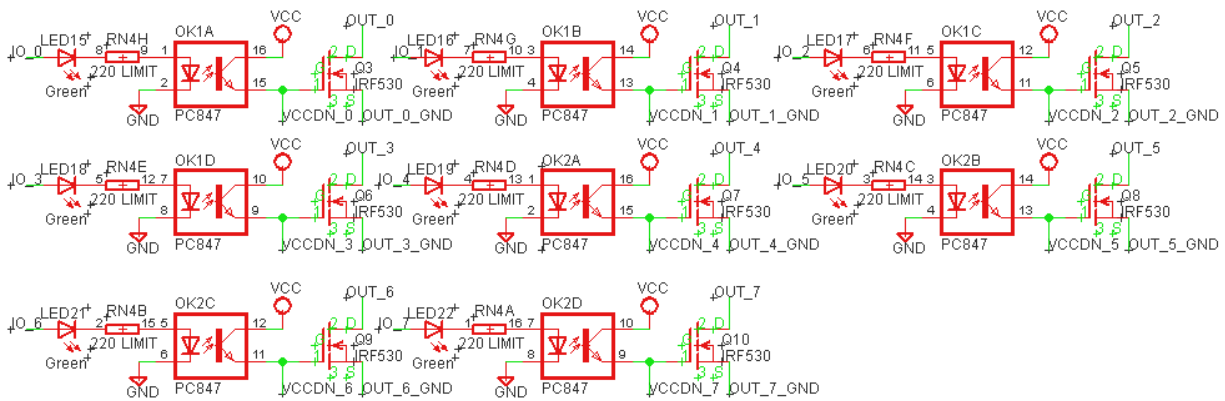

48. **POT2\_INTER: Potentiometer 2 Interface Connector (X39):** These are signals from 10K  $\Omega$  Trim Potentiometer 2 connector for any adjustable voltage signal that can be interfaced to experimental circuit on the 2.2”\*6.5” breadboard. The X39 pins connections are:

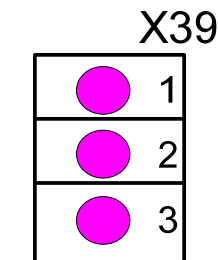

- Pin #1 → One end of the 10K  $\Omega$  Pot
- Pin #2 → Center wiper of the Pot 1
- Pin #3 → The other end of the 10K  $\Omega$  Pot

POT2\_INTER

49. **PW\_TEST\_PTS: Power Test Points (X40):** These are the test points of the power sources that produced by the trainer board. Its purpose is for testing



but can be used as additional power connection to the user's experimental circuit on the 2.2"×6.5" breadboard.

The X40 pins connections are:

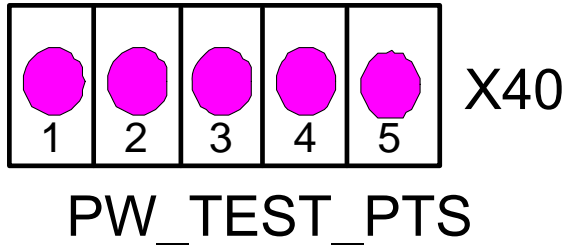

- Pin #1 → GND
- Pin #2 → +3.3V
- Pin #3 → +5V
- Pin #4 → -12V/-5V
- Pin #5 → +12V

**Note:** -12V/-5V Based on Blue Jumper Selection

**50. NEG\_V\_JMP\_SELECT: Negative Voltage Jumper Selection (X41):** A **BLUE** Jumper selection of either +5V or +12V for reference voltage to convert to either -5V or -12V voltage that can be used on the user application circuit on the 2.2"×6.5" breadboard.

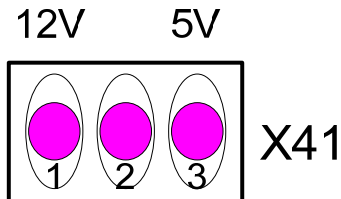

- Pin #1 → +12V
- Pin #2 → V INPUT
- Pin #3 → +5V

NEG\_V\_JMP\_SELECT

**Note:** **BLUE** Jumper on Pins #2 & #3 → Provides -5V on X44 Pin #2  
**BLUE** Jumper on Pins #1 & #2 → Provides -12V on X44 Pin #2

**51. PK3\_CONN: PICKit3 Debugger Express Connection (X42):** This connector is used for PICKit3 Debugger Express module connection to the trainer board to run programming and debugging with the PIC MCU in the ZIF socket.

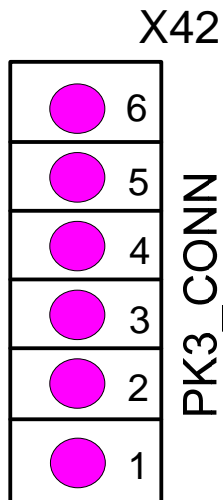

- Pin #1 → PK3\_VPP\_IN
- Pin #2 → PKC\_VDD
- Pin #3 → GND
- Pin #4 → PK3\_DAT\_IN
- Pin #5 → PK3\_CLK\_IN
- Pin #6 → PK3\_LVP

**Note:** The Arrow Mark on the PICKit3 must be lined up with Pin #1 on the X42 connector.

52. **EX\_PW\_CONN: Extra Power Source Connection (X43)**: These are the extra power sources connectors of GND, +3.3V, and +12V provided by the trainer board.

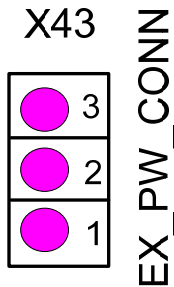

Pin #1 → GND

Pin #2 → +3.3V

Pin #3 → +12V

53. **-POWER\_CONN: Negative Power Source Connection (X44)**: These are the negative power sources connectors of GND, -5V or -12V depends on the **BLUE** Jumper on X41 provided by the trainer board.

-POWER\_CONN

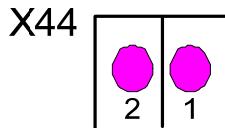

Pin #1 → GND

Pin #2 → -5V/-12V

54. **USB\_INTER: USB Interface (X45)**: The USB interface for user's USB communication with the MCU in the ZIF socket.

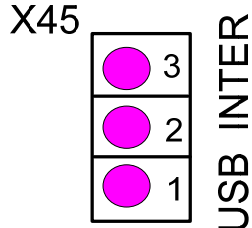

Pin #1 → USB\_D-

Pin #2 → USB\_D+

Pin #3 → GND

55. **PROG\_INTER: Programming Signal Interface (X46)**: These are the open source programming signals that come from the PICKit2 or PICKit3 programmer. These signals can be used with programming on any PIC MCU without the limited in the PIC package.

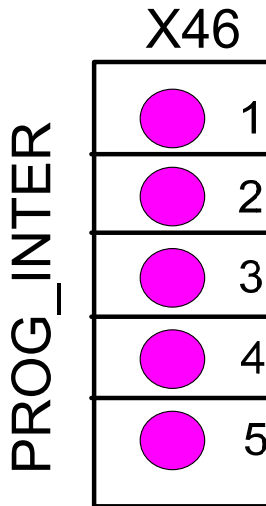

- Pin #1 → CLK
- Pin #2 → DAT
- Pin #3 → VPP
- Pin #4 → VDD
- Pin #5 → PK3\_VDD

**Note:** The user has to know the programming CLK, DAT and VPP signals of a particular PIC MCU and connect these signals to the appropriate pins of the target MCU.

**56. LPC\_INTER: LPCXpresso Module Interface (X47):** These are the connectors for LPCXpresso Programming and debugging with LPC1114FN28 that should be placed in the ZIF socket.

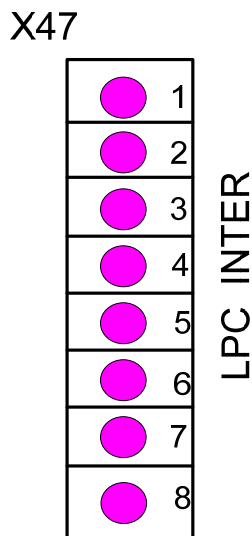

- Pin #1 → LPC\_VDD
- Pin #2 → SWDIO
- Pin #3 → SWCLK
- Pin #4 → SWO
- Pin #5 → TDI
- Pin #6 → NA
- Pin #7 → RESET
- Pin #8 → GND

**57. Switches 10-17 (S10, S11, S12, S13, S14, S15, S16, S17):** These are 8 hardware debounced SPDT slide switches to be used in experimental circuit on the 2.2”\*6.5” breadboard.

**58. LED 23-30 (Green LED23, LED24, LED25, LED26, LED27, LED28, LED29, LED3):** These are indication LEDs for signal the action on the hardware debounced slide switches 10-17.

**59. LED 3-10 (Red LED3, Green LED4, Yellow LED5, Red LED6, Green LED7, Yellow LED8, Yellow LED9, Yellow LED10):** These are indication LEDs for signal output logics on LED\_OUT0, LED\_OUT1, LED\_OUT2, LED\_OUT3, LED\_OUT4, LED\_OUT5, LED\_OUT6, LED\_OUT7 from X6 LED\_INTER connector .

60. LED 31-37 (Yellow): These are indication LEDs for input logic signals from S7 DIP switches 1-8 that come from X32, DIP\_SW\_INPUT connector.

## High Power Section

All the high power components are isolated from the low power side (there is no common ground between the low and high power components) and positioned at right side of the PCB and all the interface connectors are terminal blocks for low gauge wire high current connection flow. The graphic symbols representations are the same as they placed on the PCB.

Note: The power FETs used in the training system is IRF530 that is capable to be used for 14A operation, but due to the limited heatsink used on the trainer. The recommended operation current is 2A only.

1. **PW\_FET\_0\_CONN: The Power FET 0 Connector (X16)**: The IRF530 power FET 0/Q3 is activated by IO\_0 logic Hi, if it is activated the OUT\_0 pin will be connected to OUT\_0\_GND pin. This will allow high power on/off control to power ground terminal.

The X16 pins connections are:

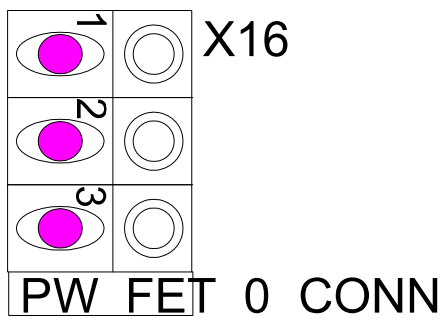

- Pin #1 → VCC ==  
Motor Power
- Pin #2 → OUT\_0 ==  
Power FET 0 Drain,  
Connected to OUT\_0\_GND If  
Activated
- Pin #3 → OUT\_0\_GND ==  
Motor Power GND

2. **PW\_FET\_1\_CONN: The Power FET 1 Connector (X17)**: The IRF530 power FET 1/Q4 is activated by IO\_1 logic Hi, if it is activated the OUT\_1 pin will be connected to OUT\_1\_GND pin. This will allow high power on/off control to power ground terminal.

The X17 pins connections are:

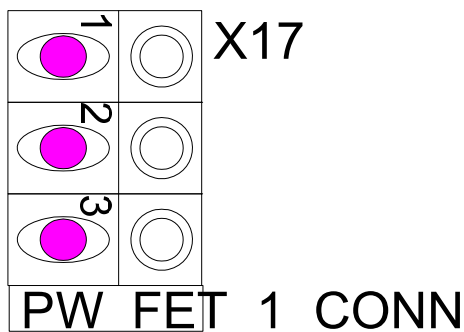

- Pin #1 → VCC ==  
Motor Power
- Pin #2 → OUT\_1 ==  
Power FET 1 Drain,  
Connected to OUT\_1\_GND If  
Activated
- Pin #3 → OUT\_1\_GND ==  
Motor Power GND

3. **PW\_FET\_2\_CONN: The Power FET 2 Connector (X18):** The IRF530 power FET 2/Q5 is activated by IO\_2 logic Hi, if it is activated the OUT\_2 pin will be connected to OUT\_2\_GND pin. This will allow high power on/off control to power ground terminal.

The X18 pins connections are:

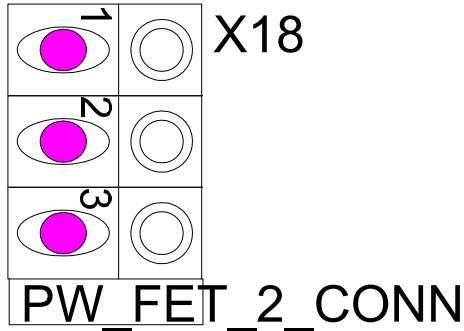

Pin #1	→ VCC	==
	Motor Power	
Pin #2	→ OUT_2	==
	Power FET 2 Drain, Connected to OUT_2_GND If Activated	
Pin #3	→ OUT_2_GND	==
	Motor Power GND	

4. **PW\_FET\_3\_CONN: The Power FET 3 Connector (X19):** The IRF530 power FET 3/Q6 is activated by IO\_3 logic Hi, if it is activated the OUT\_3 pin will be connected to OUT\_3\_GND pin. This will allow high power on/off control to power ground terminal.

The X19 pins connections are:

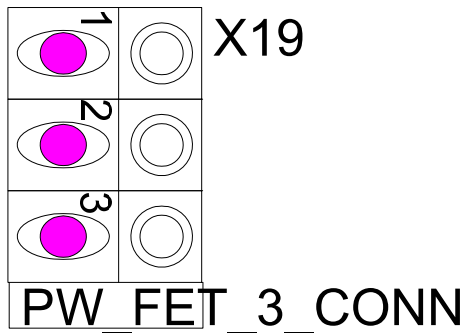

Pin #1	→ VCC	==
	Motor Power	
Pin #2	→ OUT_3	==
	Power FET 3 Drain, Connected to OUT_3_GND If Activated	
Pin #3	→ OUT_3_GND	==
	Motor Power GND	

5. **PW\_FET\_4\_CONN: The Power FET 4 Connector (X20):** The IRF530 power FET 4/Q7 is activated by IO\_4 logic Hi, if it is activated the OUT\_4 pin will be connected to OUT\_4\_GND pin. This will allow high power on/off control to power ground terminal.

The X20 pins connections are:

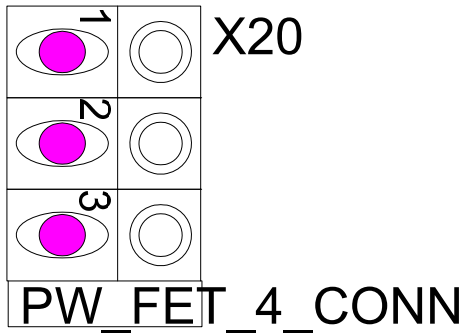

- Pin #1 → VCC ==  
Motor Power
- Pin #2 → OUT\_4 ==  
Power FET 4 Drain,  
Connected to OUT\_4\_GND If  
Activated
- Pin #3 → OUT\_4\_GND ==  
Motor Power GND

6. **PW\_FET\_5\_CONN: The Power FET 5 Connector (X21):** The IRF530 power FET 5/Q8 is activated by IO\_5 logic Hi, if it is activated the OUT\_5 pin will be connected to OUT\_5\_GND pin. This will allow high power on/off control to power ground terminal.

The X21 pins connections are:

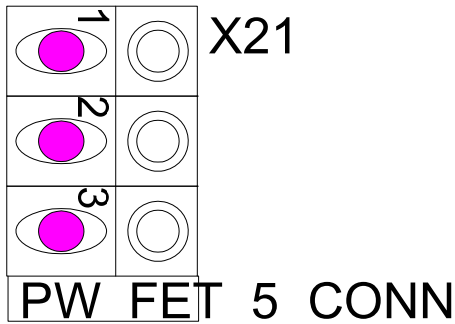

- Pin #1 → VCC ==  
Motor Power
- Pin #2 → OUT\_5 ==  
Power FET 5 Drain,  
Connected to OUT\_5\_GND If  
Activated
- Pin #3 → OUT\_5\_GND ==  
Motor Power GND

7. **PW\_FET\_6\_CONN: The Power FET 6 Connector (X22):** The IRF530 power FET 6/Q9 is activated by IO\_6 logic Hi, if it is activated the OUT\_6 pin will be connected to OUT\_6\_GND pin. This will allow high power on/off control to power ground terminal.

The X22 pins connections are:

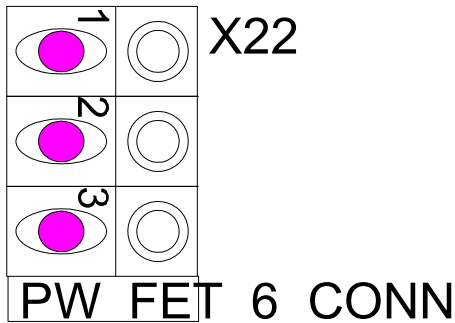

- Pin #1 → VCC ==  
Motor Power
- Pin #2 → OUT\_6 ==  
Power FET 6 Drain,  
Connected to OUT\_6\_GND If  
Activated
- Pin #3 → OUT\_6\_GND ==  
Motor Power GND

8. **PW\_FET\_7\_CONN: The Power FET 7 Connector (X23):** The IRF530 power FET 7/Q10 is activated by IO\_7 logic Hi, if it is activated the OUT\_7 pin will be

connected to OUT\_7\_GND pin. This will allow high power on/off control to power ground terminal.

The X23 pins connections are:

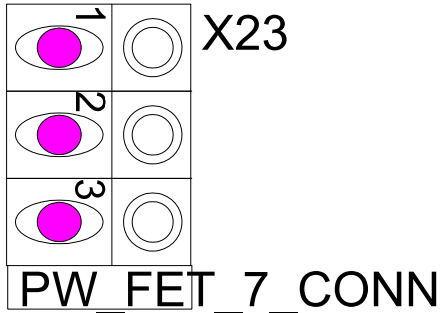

- Pin #1 → VCC ==  
Motor Power
- Pin #2 → OUT\_7 ==  
Power FET 7 Drain,  
Connected to OUT\_7\_GND If  
Activated
- Pin #3 → OUT\_7\_GND ==  
Motor Power GND

9. **VCC\_PW\_CONN: The Motor Power/High Power Connector (X24)**: This is the terminals for high power inputs to be use for motor controls. This ground is NOT the same as system +5V ground. To isolate the power ground, wires should be connected directly to power FET ground.

The X24 pins connections are:

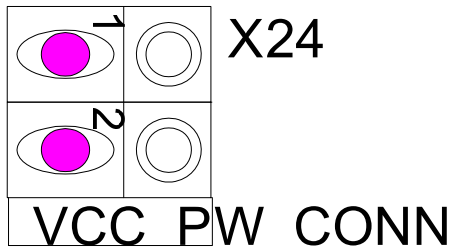

- Pin #1 → VCC
- Pin #2 → GND

10. **HB1\_INTER: H-Bridge 1 Connector (X25)**: This is H-Bridge #1 connector for applications with IRF530 controls on high power Unipolar stepper motor or DC motor directions.

The X25 pins connections are:

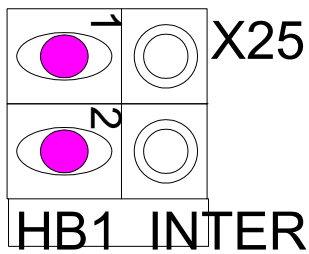

- Pin #1 → HB1\_1
- Pin #2 → HB1\_2

The associate circuit of this X25 connector is:



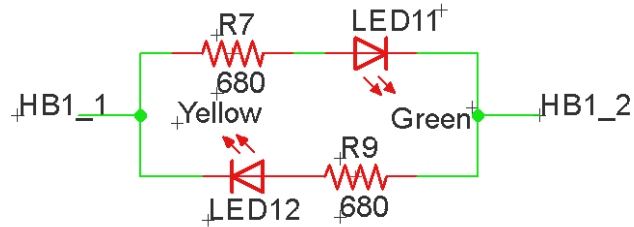

**Note:** IRF530/Q3 is activated via IO\_0 logic pin 1 in X38 interface connector.  
 IRF530/Q4 is activated via IO\_1 logic pin 2 in X38 interface connector.  
 IRF530/Q5 is activated via IO\_2 logic pin 3 in X38 interface connector.  
 IRF530/Q6 is activated via IO\_3 logic pin 4 in X38 interface connector.  
 All the logic signals are isolated through optical isolator between MCU and motor power signals.

Users need to connect proper wires on terminal blocks (X16, X17, X18, & X19) to make the H-Bridge #1, the followings are the suggested connections and their associated circuits stated in item #11.

- (1) VCC (motor power, any Pin #1 on X16, X17, X18 or X19) to OUT\_0 (Pin #2 on X16) & OUT\_1 (Pin #2 on X17)
- (2) OUT\_0\_GND (Pin #3 on X16) & OUT\_2 (Pin #2 on X18) & HB1\_1 (Pin #1 on X25)
- (3) OUT\_1\_GND (Pin #3 on X17) & OUT\_3 (Pin #2 on X19) & HB1\_2 (Pin #2 on X25)
- (4) OUT\_2\_GND (Pin #3 on X18) & OUT\_3\_GND (Pin #3 on X19) to Motor Power GND (Pin #2 on X24)
- (5) HB1\_1 (Pin #1 on X25) & HB1\_2 (Pin #2 on X25) to Motor Terminals.

Activate IO\_0 and IO\_3 to and disable IO\_1 and IO\_2 to drive DC motor in one direction.

Activate IO\_1 and IO\_2 to and disable IO\_0 and IO\_3 to drive DC motor in the other direction.

**Note:** In this configuration, never active both IRF530/Q3 (IO\_0) & IRF530/Q5 (IO\_2) and/or both IRF530/Q4 (IO\_1) & IRF530/Q6 (IO\_3) at the same time. This will cause a direct short of VCC to GND.

**11. The Equivalent H-Bridge (HB1) Circuit with IO and IRF530:** The equivalent H-Bridge 1 circuit connections that described in item #10 are presented as:  
 (Note: the IO\_0, IO\_1, IO\_2, IO\_3 are not directly connected (they go through the optical isolator) to the gates of the associate IRFs)

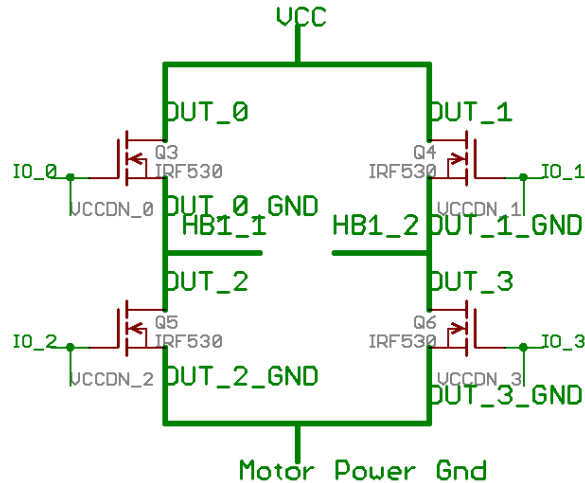

12. **LED11/Green & LED12/Yellow:** These are current direction flow indicators for H-Bridge #1 control applications.

13. **HB2\_INTER:** *H-Bridge 2 Connector (X26):* This is H-Bridge #2 connector for applications with IRF530 controls on high power Unipolar stepper motor or DC motor directions.

The X26 pins connections are:

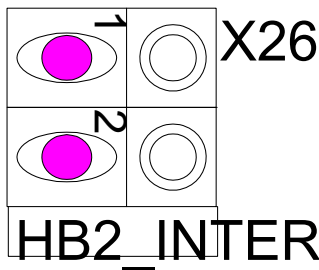

Pin #1 → HB2\_1

Pin #2 → HB2\_2

The associate circuit of this X26 connector is:

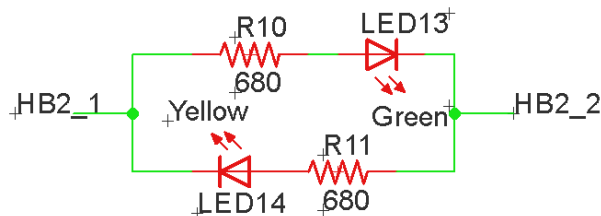

**Note:** IRF530/Q7 is activated via IO\_4 logic pin 5 in X38 interface connector.  
 IRF530/Q8 is activated via IO\_5 logic pin 6 in X38 interface connector.  
 IRF530/Q9 is activated via IO\_6 logic pin 7 in X38 interface connector.  
 IRF530/Q10 is activated via IO\_7 logic pin 8 in X38 interface connector.  
 All the logic signals are isolated through optical isolator between MCU and motor power signals.

Users need to connect proper wires on terminal blocks (X20, X21, X22, X23) to make the H-Bridge #2, the followings are the suggested connections and their associated circuits stated in item #14.

- (1) VCC (motor power, any Pin #1 on X20, X21, X22 or X23) to OUT\_4 & (Pin #2 on X20) OUT\_5 (Pin #2 on X21)
- (2) OUT\_4\_GND (Pin #3 on X20) & OUT\_6 (Pin #2 on X22) & HB2\_1 (Pin #1 on X26)
- (3) OUT\_5\_GND (Pin #3 on X21) & OUT\_7 (Pin #2 on X23) & HB2\_2 (Pin #2 on X26)
- (4) OUT\_6\_GND (Pin #3 on X22) & OUT\_7\_GND (Pin #3 on X23) to Motor Power GND (Pin #2 on X24)
- (5) HB2\_1 (Pin #1 on X26) & HB2\_2 (Pin #2 on X26) to Motor Terminals.

Activate IO\_4 and IO\_7 to and disable IO\_5 and IO\_6 to drive DC motor in one direction.

Activate IO\_5 and IO\_6 to and disable IO\_4 and IO\_7 to drive DC motor in the other direction.

**Note:** In this configuration, never active both IRF530/Q7 (IO\_4) & IRF530/Q9 (IO\_6) and/or both IRF530/Q8 (IO\_5) & IRF530/Q10 (IO\_7) at the same time. This will cause a direct short of VCC to GND.

14. **The Equivalent H-Bridge (HB2) Circuit with IO and IRF530:** The equivalent H-Bridge 1 circuit connections that described in item #4 are presented as: (Note: the IO\_4, IO\_5, IO\_6, IO\_7 are not directly connected (they go through the optical isolator) to the gates of the associate IRFs)

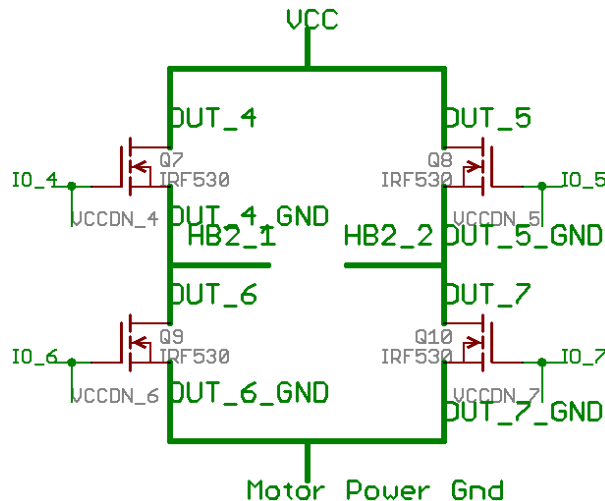

15. **LED13/Green & LED14/Yellow:** These are current direction flow indicators for H-Bridge #2 control applications.

16. **Optical Isolator and IRF530 Connection:** The actual circuit that uses optical isolator with IRF530 on/off control is presented as following:

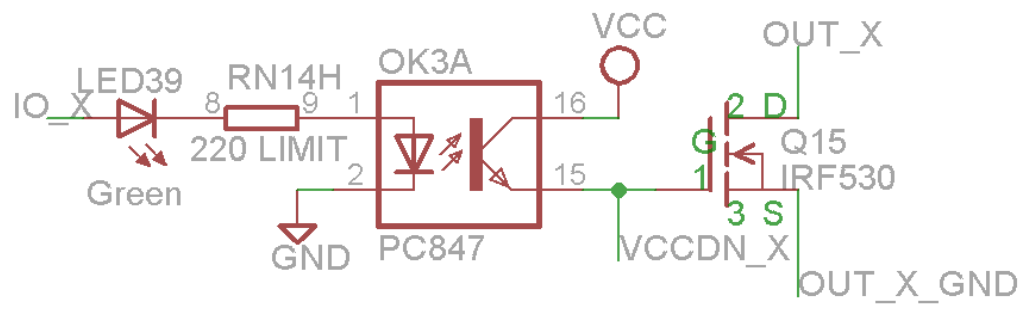

## Software Operations:

### PICKIT2 PIC Programming

Download the PICKIT2 2.61V: This software is available

[www.microchip.com/pickit2](http://www.microchip.com/pickit2)

After the installation and execute the software, you should be able to see a menu screen like this:

1. **Device**: It is an indication of what type of PIC family member is currently in the ZIF socket.
2. **Configuration**: It indicates what configuration word is in your source code setting.
3. **Status Bar**: It indicates the communication status.
4. **Read**: It reads the content of the PIC flash and EEPROM.

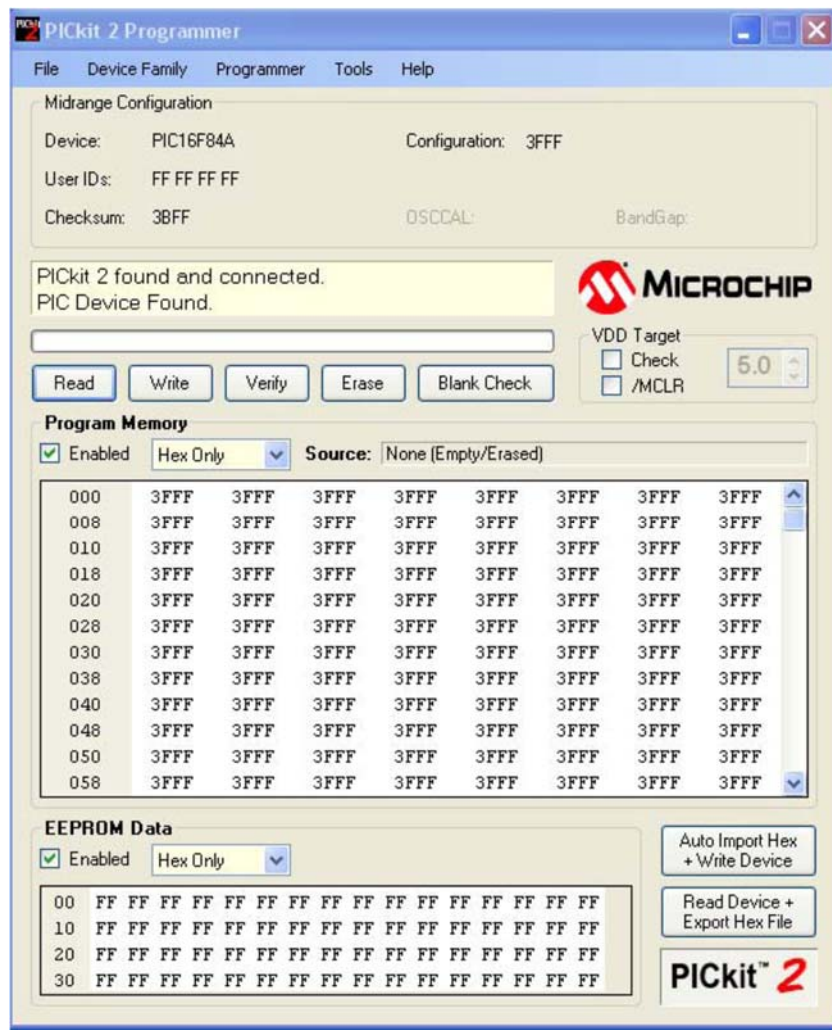

5. **Write**: It writes the source code (.HEX file) to the PIC flash memory.
6. **Verify**: It verifies the content of the PIC with the buffer memory in a PC.
7. **Erase**: It erases the content of flash and EEPROM memory from the PIC.
8. **Blank Check**: It checks the content of flash and EEPROM memory for blank.
9. **Program Memory**: It indicates the flash memory content of the PIC or the PC buffer memory.
10. **EEPROM Memory**: It indicates the EEPROM memory content of the PIC or the PC buffer memory.
11. **File Menu - Import Hex**: Load the .HEX into the PC buffer memory. This has to be done before any programming of a PIC can proceed.
12. **File Menu - Export Hex**: Write the PC buffer memory to a file on the PC. This enables you to upload the flash memory content of the PIC to a PC and make it a .HEX file.
13. **Device Family Menu**: This allows you to choose different PIC family member for programming purpose.
14. **Programmer Menu**: This is the same as Read, Write, Verify, Erase, Blank Check as describe before.
15. **Tools Menu– Check Communication**: This allows you to check the USB communication between the programmer board and a PC connection.

**Note**: There are features in the PICKIT2 software that is related to Microchip hardware but not usable in this ODU programmer. NOT every function in the PICKIT2 software is implemented in this programmer hardware design.

## MPLAB IDE PIC Programming

**Note: MPLAB does not support PIC16F84A programming but it works with other PIC MCUs such as PIC16F877A.**

1. Under the main manual, select **Configure**, choose **Select Device ...**

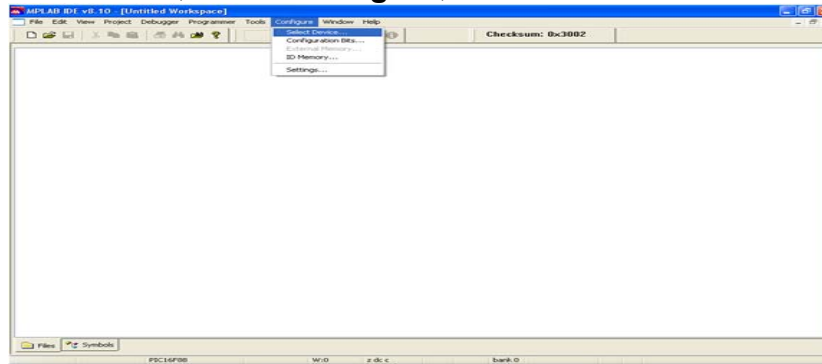

2. From the Select Device manual, choose proper target MCU that you are using for program:

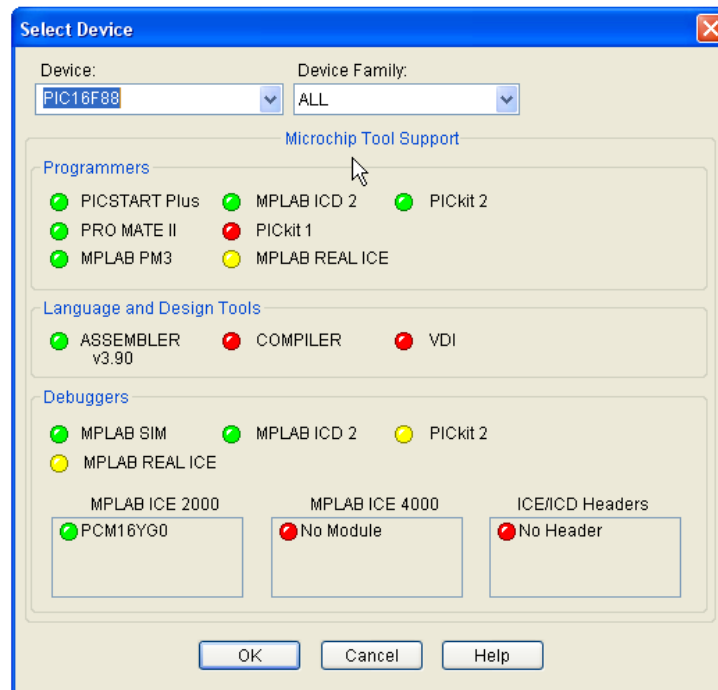

**Note:** There are limited numbers of MCU that MPLAB IDE support PICKIT2 programming. PIC16F84A is not supported, but PIC16F88 and PIC16F877A are supported by MPLAB IDE/PICKIT2 programming.

3. After you done with the select device choice, under the MPLAB main manual, select **Programmer**, choose **Select Programmer**, choose **4 PICKIT2**

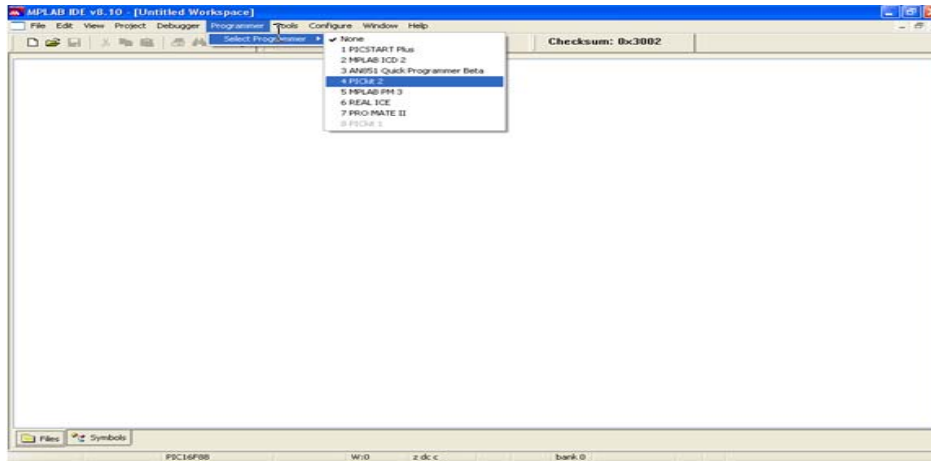

4. After you choose the PICKIT2, the software will start the communication with the PIC Training System, if everything goes well, you should see this:

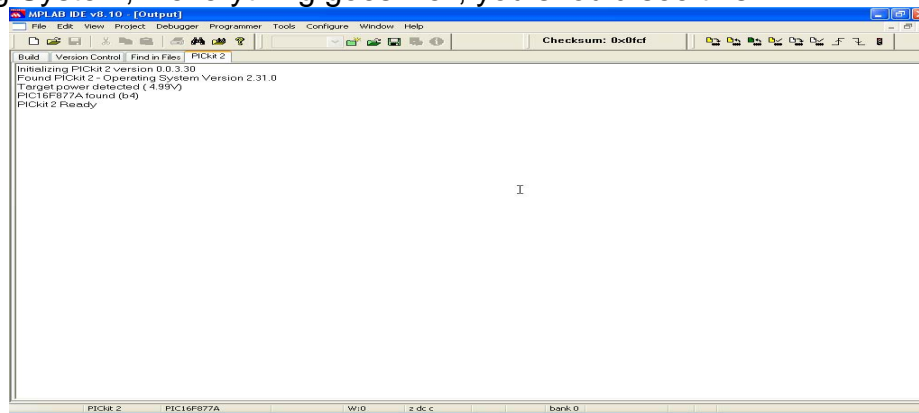

5. If you have the .HEX file ready, you can start programming the target MCU with MPLAB, under the main manual, select **File**, choose **Import...**

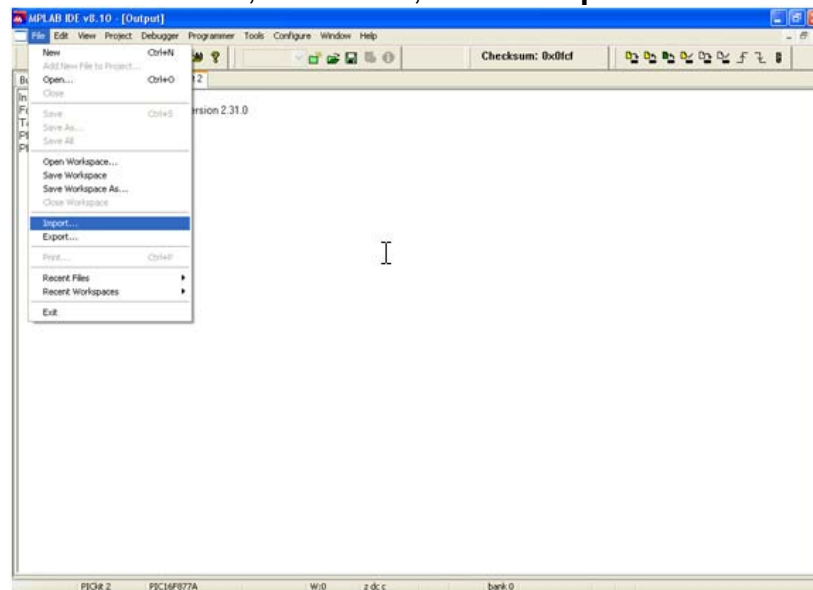



- From here go to your proper folder and locate your .HEX file, then choose **Open**

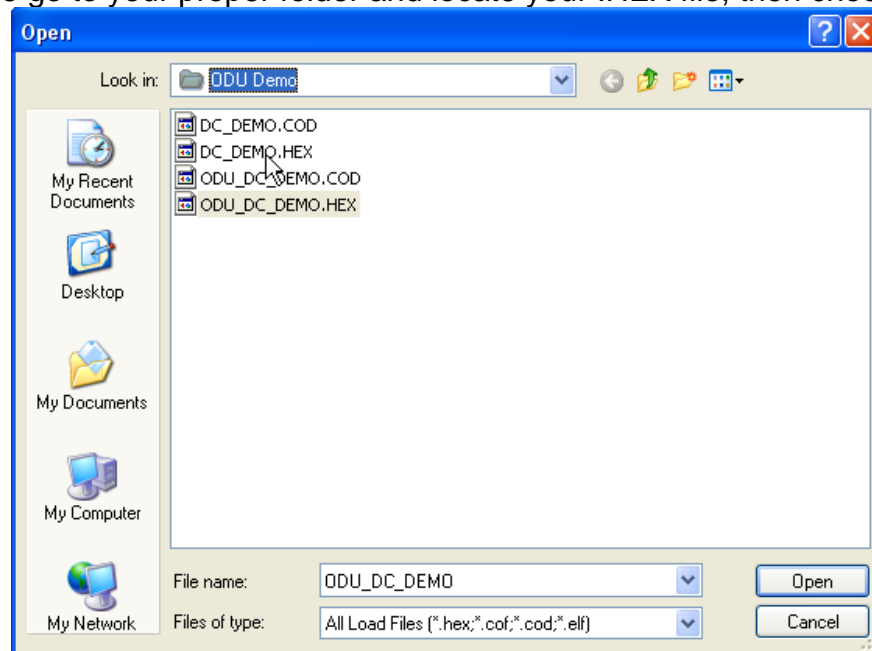

- Under MPLAB main manual, select **Programmer**, choose **Program**

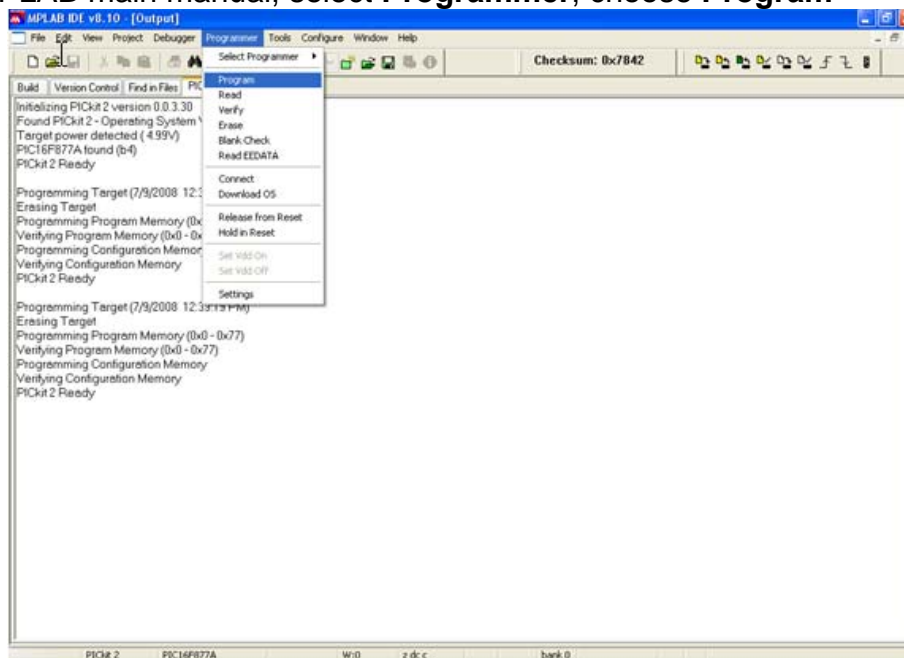

- The software will automatically program the target MCU and report its success on the screen as present above.